

Vipros 255 With Fanuc 18P Control Layout Drawings



Amada America Inc.
7025 Firestone Blvd.
Buena Park CA. 90621
Phone: (714) 739 2111
Fax.: (714) 739 4099
Email info@amada.com

Warning

- ❑ Qualified personnel must complete all work.
- ❑ Do not apply power to the Vipros 255 until an A.E.S.I. (Amada Engineering and Service Incorporated) Engineer is present and has instructed you to do so.
- ❑ Not all information required to install the Vipros 255 is included with this document. Specific details for proper installation are found in the document *Vipros 255 With 18P Control Pre-installation Guide* available at the Amada America Internet web site at <http://www.amada.com>.
- ❑ Considerable effort has been made to ensure that this manual is free of inaccuracies and omissions. However, as we are constantly improving our product, some of the data contained herein may be out of date. Please check our Internet site, <http://www.amada.com>, for the latest release of this document.

Contents

Planning the Location of the Vipros 255	4
Plan View - Vipros 255	5
Plan View - Vipros 255 (shown with optional V255hs Conveyor)	6
Plan View - Vipros 255 (shown with optional V255hs Conveyor and NJMP1225 Loader)	7
End View - Vipros 255	8
Elevation View - Vipros 255	9
Chiller Placement	10

Planning the Location of the Vipros 255

The following diagrams provide the details for positioning the Vipros 255.

- No obstacles are allowed in the worksheet travel area and the ceiling must be at least 40" above the Vipros 255.
- All of the recommended maintenance areas should be used, but at a minimum the doors of the NC unit must be able to be opened. Any reduction of the listed maintenance areas may increase time and expense of installation and maintenance.
- The Vipros 255 machine and control must be protected from direct sunlight or other heat sources. Direct exposure to direct heating sources such as infrared heaters have been shown to affect punch and die alignment.
- The positioning of the SBC EX3.0 Chiller is very flexible

Plan View - Vipros 255

Electrical Requirements

(E1) Vipros 255
 230 / 460 / 3 / 60 ±10%, 22 kVA
 68 amps @ 230 / 3 / 60 VAC
 34 amps @ 460 / 3 / 60 VAC

(E2) SBC EX3.0 Chiller
 230 or 460 / 3 / 60 ±10%, 15 kVA
 38 amps @ 230 / 3 / 60 VAC
 19 amps @ 460 / 3 / 60 VAC

Compressed Air Requirements

(P1) Vipros 255
 80 psi @ 8.8 ft³/min.

Operator Control Station

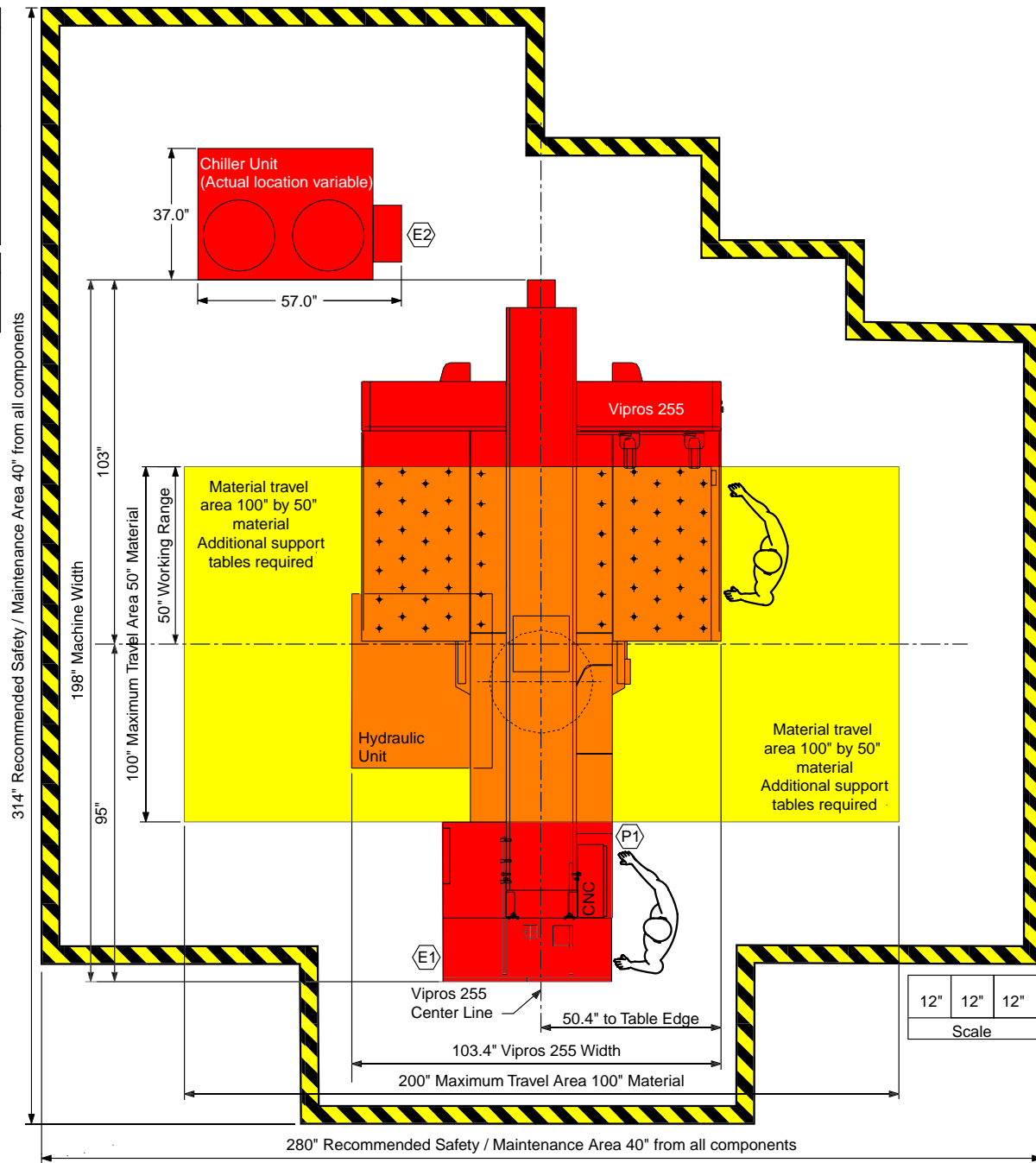

Plan View - Vipros 255 (shown with optional V255hs Conveyor)

Electrical Requirements	
E1 Vipros 255	230 / 460 / 3 / 60 ±10%, 22 kVA 68 amps @ 230 / 3 / 60 VAC 34 amps @ 460 / 3 / 60 VAC
E2 SBC EX3.0 Chiller	230 or 460 / 3 / 60 ±10%, 15 kVA 38 amps @ 230 / 3 / 60 VAC 19 amps @ 460 / 3 / 60 VAC
E3 V255hs Conveyor	208 - 230 / 460 / 3 / 60 ±10%, .8 kVA 2.1 amps @ 208 / 3 / 60 VAC 2.0 amps @ 230 / 3 / 60 VAC 1.0 amps @ 460 / 3 / 60 VAC
Compressed Air Requirements	
P1 Vipros 255	80 psi @ 8.8 ft ³ /min.
Operator Control Station	
	

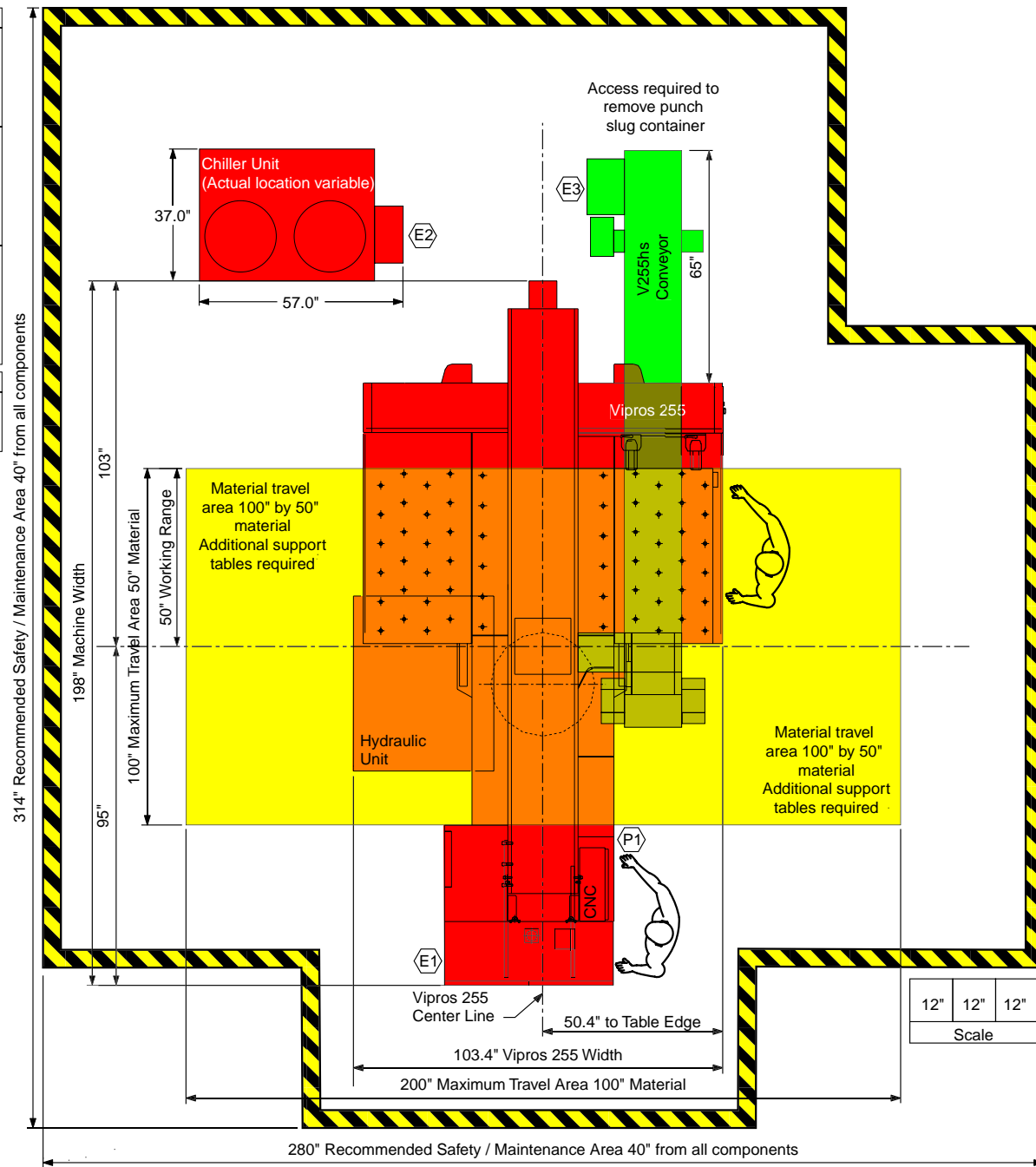

Plan View - Vipros 255 (shown with optional V255hs Conveyor and NJMP1225 Loader)

Electrical Requirements	
(E1) Vipros 255	230 / 460 / 3 / 60 ±10%, 22 kVA 68 amps @ 230 / 3 / 60 VAC 34 amps @ 460 / 3 / 60 VAC
(E2) SBC EX3.0 Chiller	230 or 460 / 3 / 60 ±10%, 15 kVA 38 amps @ 230 / 3 / 60 VAC 19 amps @ 460 / 3 / 60 VAC
(E3) V255hs Conveyor	208 - 230 / 460 / 3 / 60 ±10%, .8 kVA 2.1 amps @ 208 / 3 / 60 VAC 2.0 amps @ 230 / 3 / 60 VAC 1.0 amps @ 460 / 3 / 60 VAC
(E4) MP1225 Loader	200 / 3 / 60 ±10%, 10 Kva To operate at 230 / 460 VAC a step up transformer is required with the following service is required 29 amps @ 200 / 3 / 60 VAC 26 amps @ 230 / 3 / 60 VAC 13 amps @ 460 / 3 / 60 VAC
Compressed Air Requirements	
(P1) Vipros 255	80 psi @ 8.8 ft3/min.
(P2) MP1225 Loader	75 psi @ 31.8 ft3/min.
Operator Control Station	
	

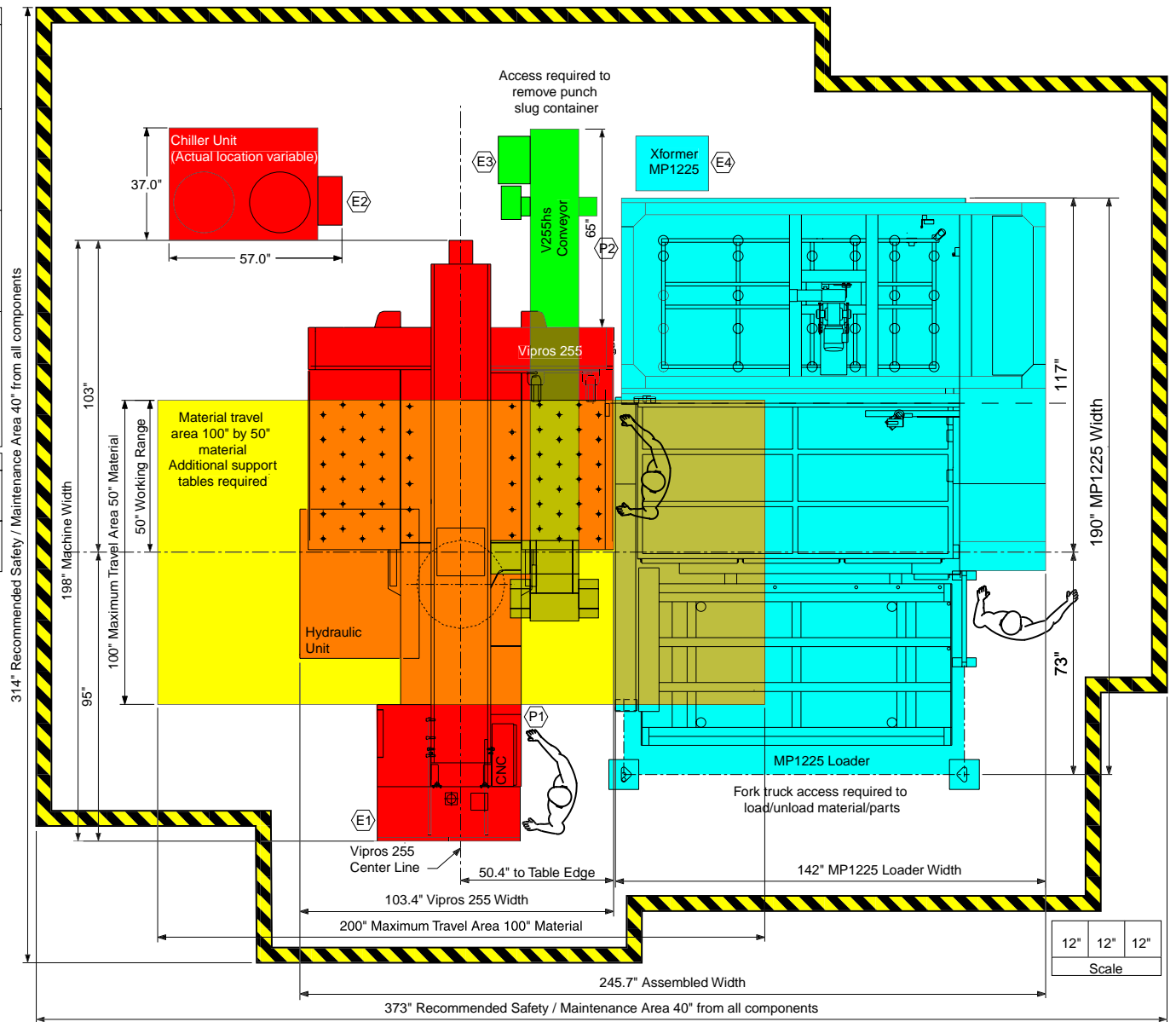

End View - Vipros 255

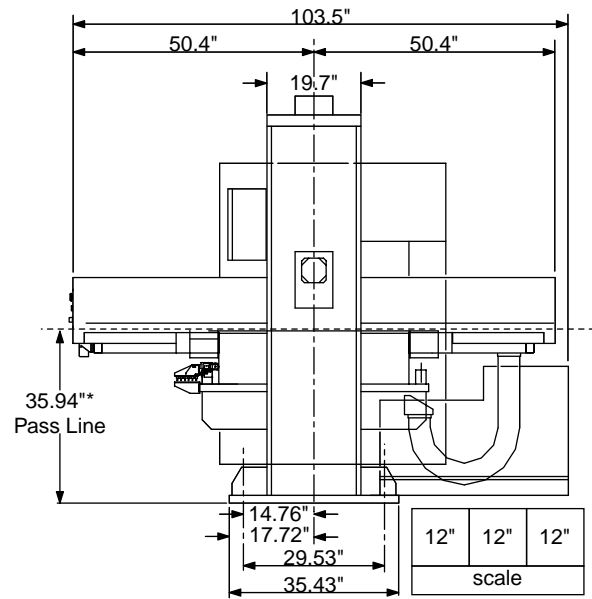

*dimension subject to change with installed optional equipment

Elevation View - Vipros 255

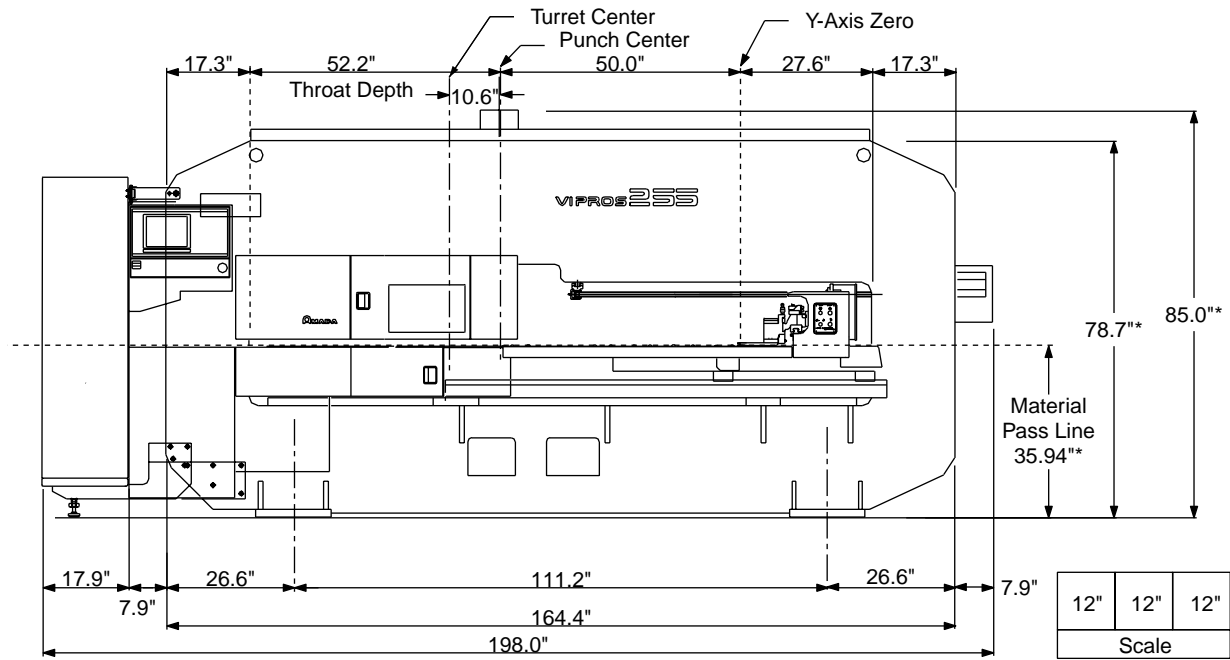

*Material Pass Line will vary depending on installed options

Chiller Placement

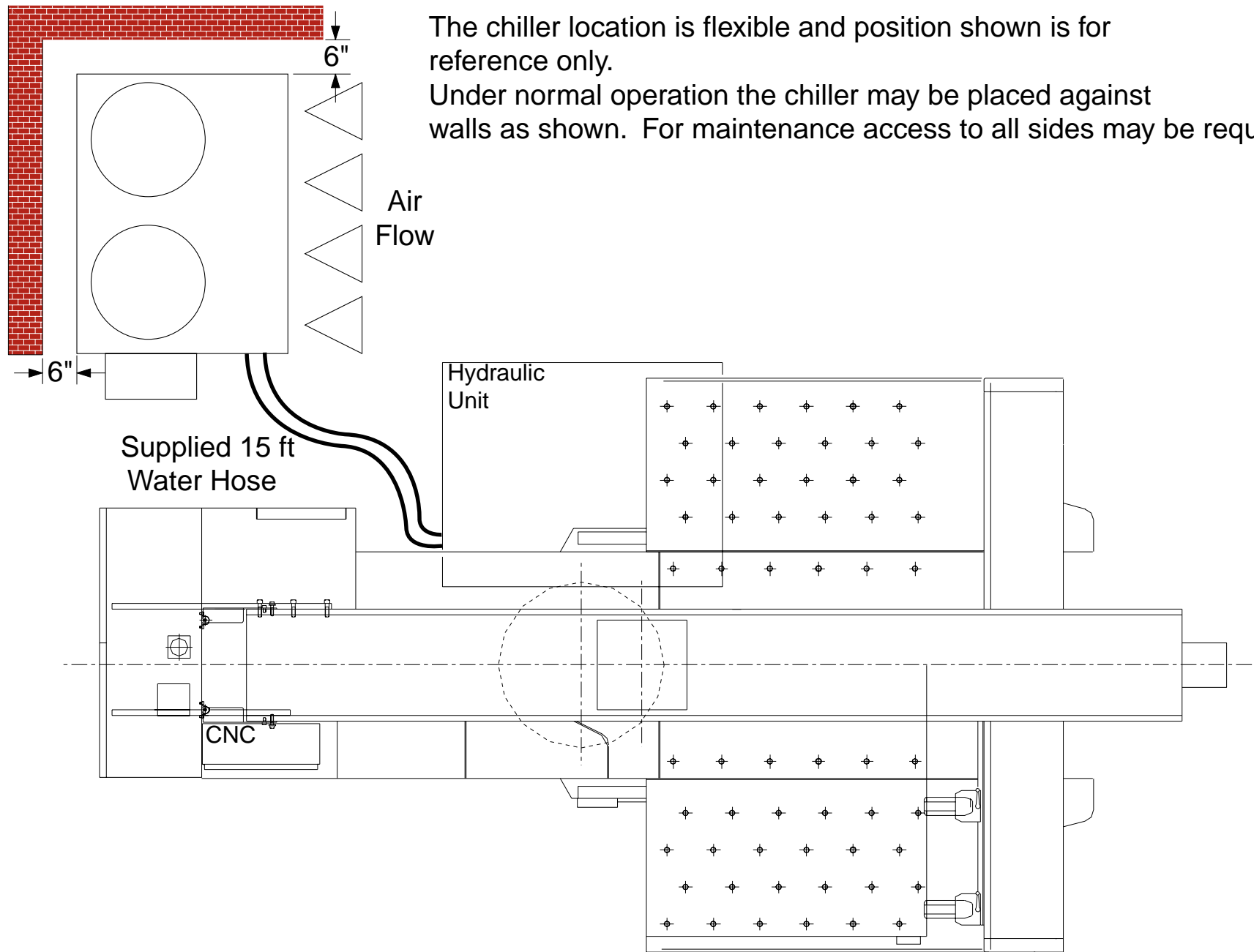

The chiller location is flexible and position shown is for reference only.
 Under normal operation the chiller may be placed against walls as shown. For maintenance access to all sides may be required.