

Vipros 568 User Pre-installation Guide



Amada America Inc.
7025 Firestone Blvd.
Buena Park CA. 90621
Phone: (714) 739 2111
Fax: (714) 739 4099
e-mail: info@amada.com

Warning

- Qualified personnel must complete all work.
- Do not apply power to the Vipros 568 until an A.E.S.I. (Amada Engineering and Service Incorporated) Engineer is present and has instructed you to do so.

Contents

- Introduction 5
- Motion Package Specifications 6
- Punching System Specifications 7
 - 62 Station 2 Auto/Index Turret Layout 8
 - 58 Station 4 Auto/Index Turret Layout 9
- Fanuc O4PC CNC Controller 10
- Supply Requirements 11
 - Installing the Electrical Power Supply 12
 - Installing the Air Supply 13
- Planning the Location of the Vipros 568 14
 - Lifting the Machine 15
 - Machine Dimensions - Plan View 16
 - Machine Dimensions - Elevation View 17
 - Machine Dimensions - End View 18
 - Maintenance Areas 19
- The Chiller 20
 - Chiller Cautions 20
 - Chiller Placement 21
 - Connections 22
- Foundation Requirements 23
- Machine Anchoring Requirements 24
 - Floor J-bolt Mounting Hole Detail (saw cut hole) 24
 - Floor J-bolt Mounting Hole Plan View (saw cut hole) 25
 - Alternative Floor J-bolt Mounting Hole Detail (Core Drill) 26
 - Alternative J-bolt Mounting Method Plan View (Core Drill) 27
 - Floor J-bolt Mounting Procedure 28
- Foundation Mounting Procedure 30
 - Foundation J-bolt Detail 30
 - Foundation Plan View 31

Foundation Elevation View 32

Removing the Protective Coating..... 33

Machine Leveling 34

 Rocking Test..... 35

 Floor Condition: Crowning 36

 Floor Condition: Slope 37

 Leveling Procedure 38

Introduction

This manual describes the tasks that the purchaser of a Vipros 568 must complete before calling the service organization to complete the installation and operator training.

An overview of the preparations is as follows:

- Plan the location of the Vipros 568 in the shop, taking into account all the maintenance areas indicated on the floor plan.
- Prepare the Vipros 568 floor area as required.
- Uncrate the Vipros 568, Fanuc O4PC control, and SBC 5.5 Chiller and place them on the floor.
- Install the air supply.
- Install the electrical supply.
- Remove the protective coating from the surface of the Vipros 568.
- Anchor the Machine to the floor or foundation using the appropriate method described in this document

Note: It is the purchaser's responsibility to install any safety devices to ensure the safety area.

Motion Package Specifications

Travel Method	X and Y axes work piece movement
Control Method	X, Y, T & C
Drive Motors	Fanuc AC Servo (X, Y, T, C)
Maximum Sheet Size	157.480" (X) by 60.000" (Y) with one repositioning cycle
Maximum Sheet Thickness	0.375"
Maximum Material Weight	440lb.
Maximum Axis Travel	78.740"(X) by 60.000"(Y)
Max. Linear Table Speed	1968 ipm
Punching Accuracy	±0.005"
Positioning Accuracy	±0.001"
Repeatability	±0.001"

Punching System Specifications

Press Capacity	55 Tons		
Press Stroke	1.256"		
Stroke Rate @ 25 tons	Stroke Length	Pitch	Stroke Rate
	0.236"	0.079"	320
	0.315"	1.000"	200
Maximum Hole Diameter	4.500"		
Tool Type	Amada Thick Turret		
Turret Rotation Speed	25 RPM		

62 Station 2 Auto/Index Turret Layout

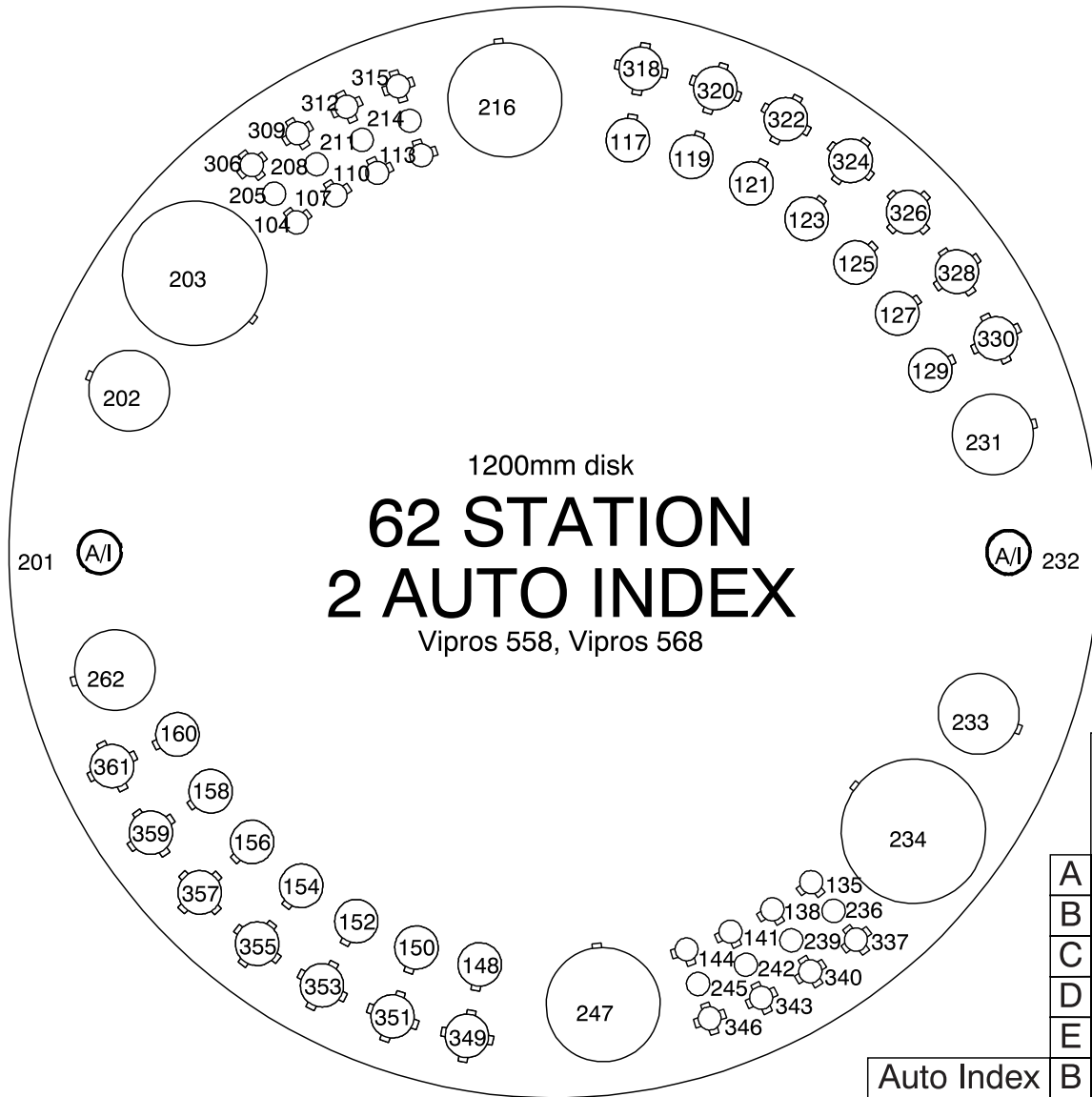

	Maximum Size	Number of Stations (Keyed)
A	1/2" (12.7mm)	24 (16)
B	1 1/4" (31.7mm)	28 (28)
C	2" (50.8mm)	4 (4)
D	3 1/2" (88.9mm)	2 (2)
E	4 1/2" (114.3mm)	2 (2)
Auto Index	B 1 1/4" (31.7mm)	2 (2)

58 Station 4 Auto/Index Turret Layout

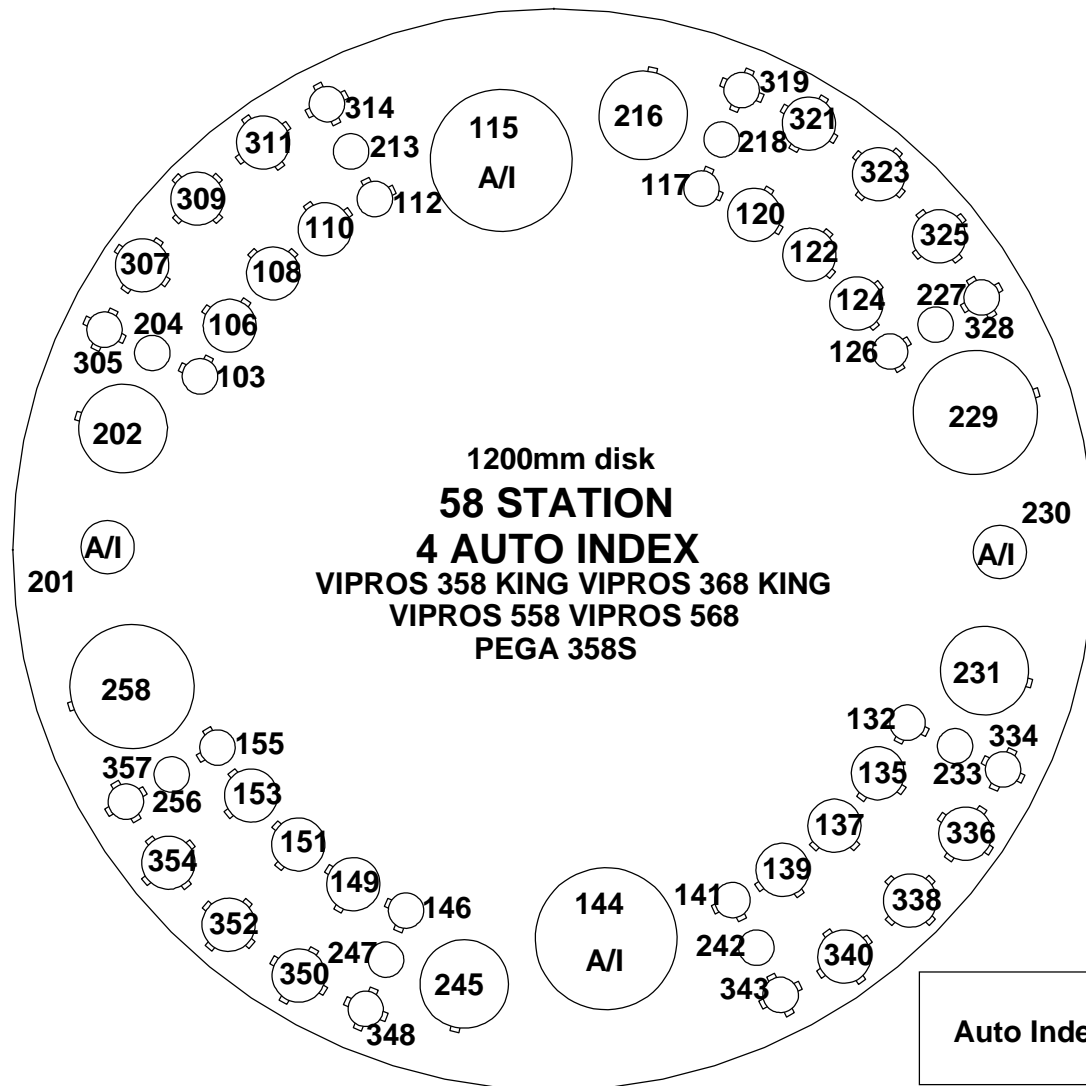

	Maximum Size Round	Number of Stations (Keyed)
A	1/2" (12.7mm)	24 (16)
B	1 1/4" (31.7mm)	24 (24)
C	2" (50.8mm)	4 (4)
D	3 1/2" (88.9mm)	2 (2)
Auto Index	B	2 (2)
	E	4 1/2" (114.3mm)

Fanuc O4PC CNC Controller

Model	Fanuc O4PC
Control Function	X, Y, T & C
Input Method	MDI, Paper Tape, DNC
Minimum Command Unit	0.001" (X, Y) .01 ⁰ (C)
Minimum Travel Unit	0.001" (X, Y) .01 ⁰ (C)
Operating Modes	Automatic, MDI & Manual
Display Modes	Program Contents, Position Information, Program Check, Parameters, Tool Hit Counter, Self Diagnostics
Interlock Displays	Oil Temperature, Door Open

Supply Requirements

Electrical Power Supply Vipros 568 SBC-5.5 Chiller*	230 / 460 3ph $\pm 10\%$, 28 kVA 230 or 460 3ph $\pm 10\%$, 15 kVA
Air Supply	80 psi @ 8.8 ft ³ /min.

*Voltage must be specified when machine is ordered

Installing the Electrical Power Supply

The Vipros 568 requires two electrical power sources. The first power source is supplied to the Fanuc O4PC control. The Fanuc O4PC control should be supplied from a separate power line from those used for welding machines or other machines that produce electrical noise. The second source is connected to the SBC-5.5 chiller.

- ❑ The Vipros 568 electrical inlet is 60" above floor level inside the magnetic enclosure located to the rear of the Fanuc O4PC control.
- ❑ The SBC-5.5 chiller electrical inlet is 48" above floor level at the end of the chiller.

Vipros 568

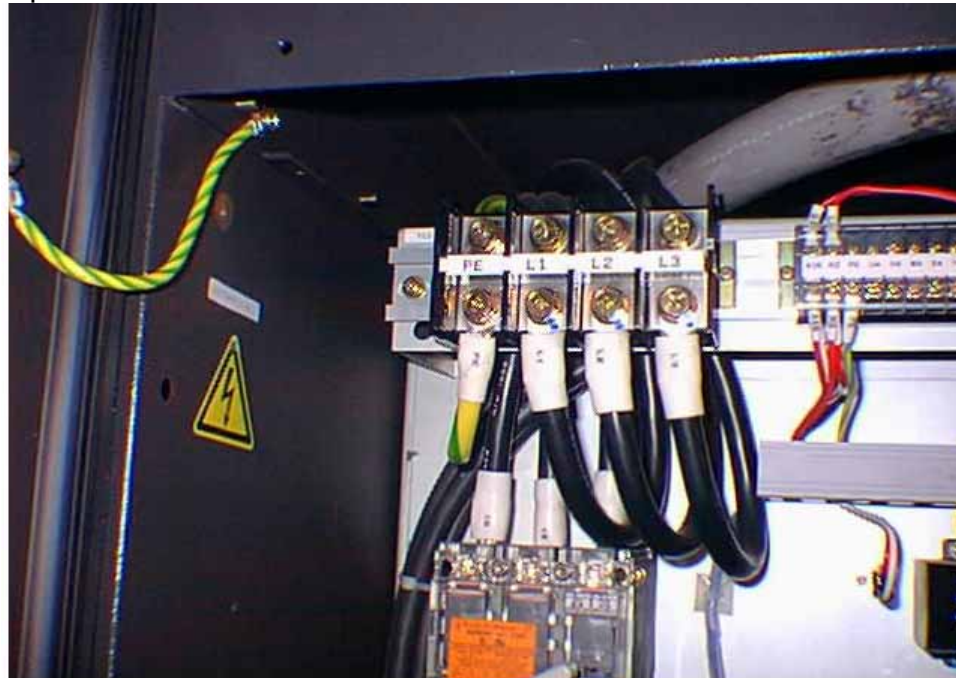

SBC 5.5 Chiller

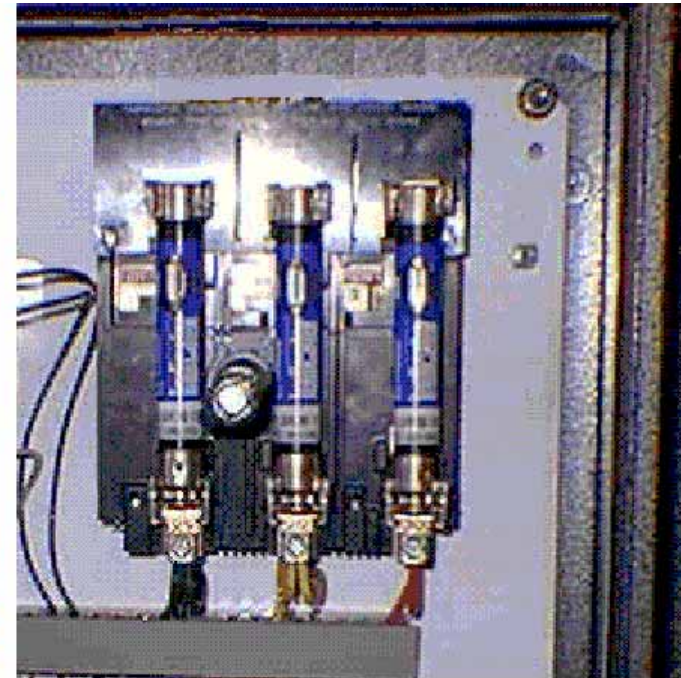

Installing the Air Supply

The Vipros 568 must be connected to a compressed air system by hose or pipe. The compressed air must be clean and dry.

Please note the following:

- ❑ The minimum inner pipe diameter is ½".
- ❑ The air pressure required is 80 psi.
- ❑ The air volume required is 8.8 ft³/min.
- ❑ The air inlet is approximately 16" above the floor level at the rear of the Vipros 568.

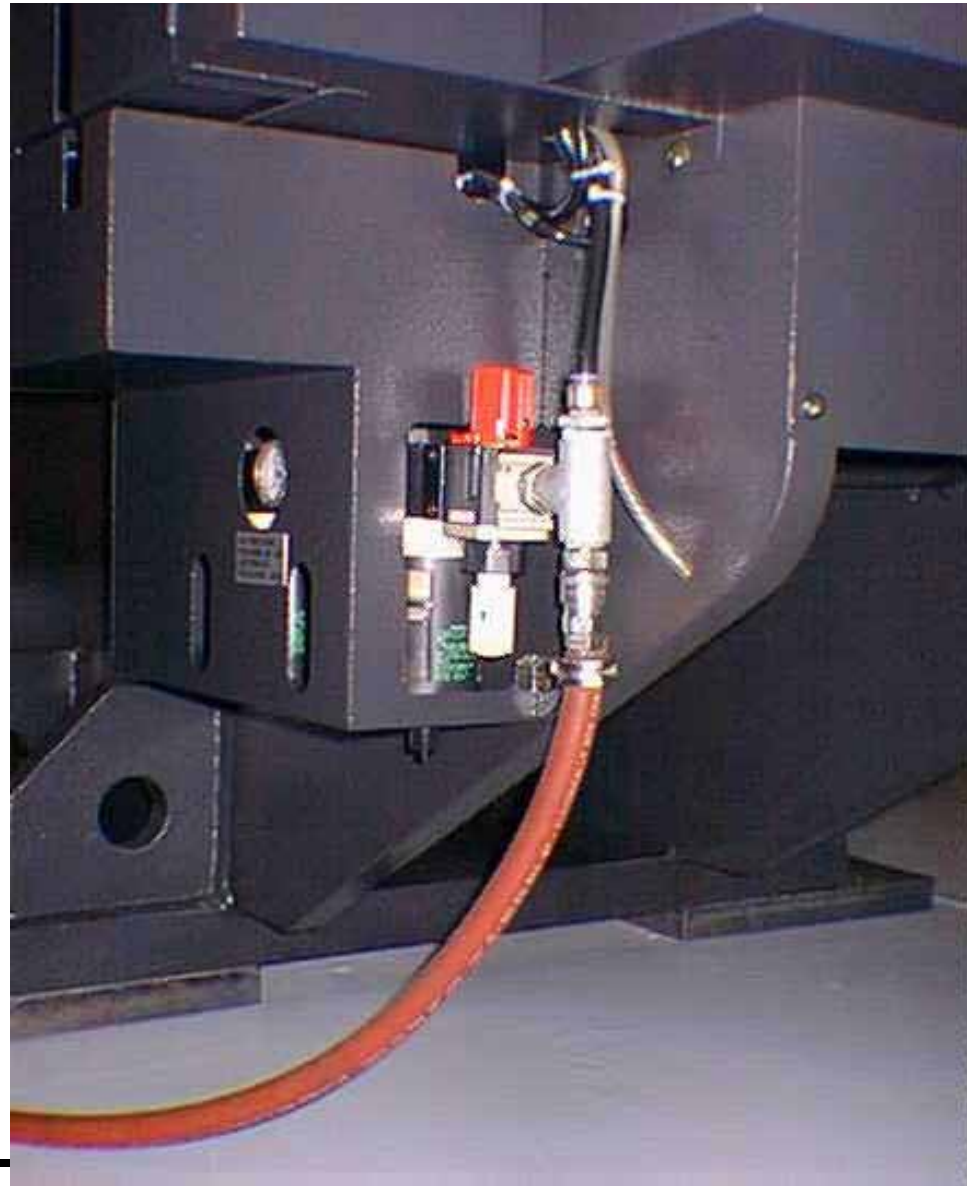

Planning the Location of the Vipros 568

The following diagrams provide the details for positioning the Vipros 568.

- No obstacles are allowed in the worksheet travel area and the ceiling must be at least 40" above the top of the Vipros 568.
- All of the maintenance safety areas recommended should be used, but at a minimum you must ensure that the doors of the Fanuc O4PC CNC unit can be opened.
- The Vipros 568, Fanuc O4PC control, and SBC-5.5 chiller must be protected from direct sunlight or other heat sources.
- The floor must be of sufficient quality to adequately support the weight of the machine. See *Floor Mounting Procedure* for details.

Lifting the Machine

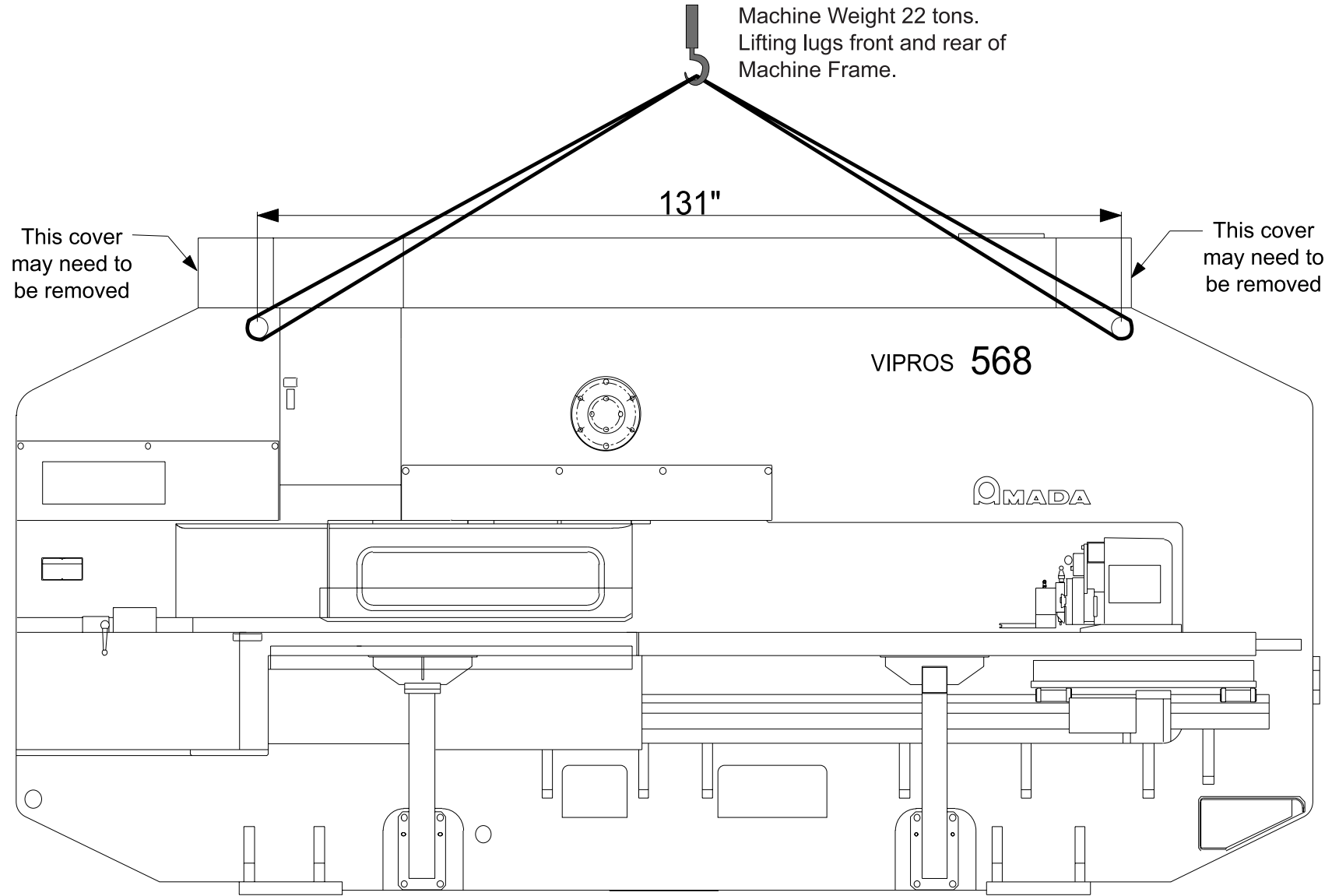

Machine Dimensions - Plan View

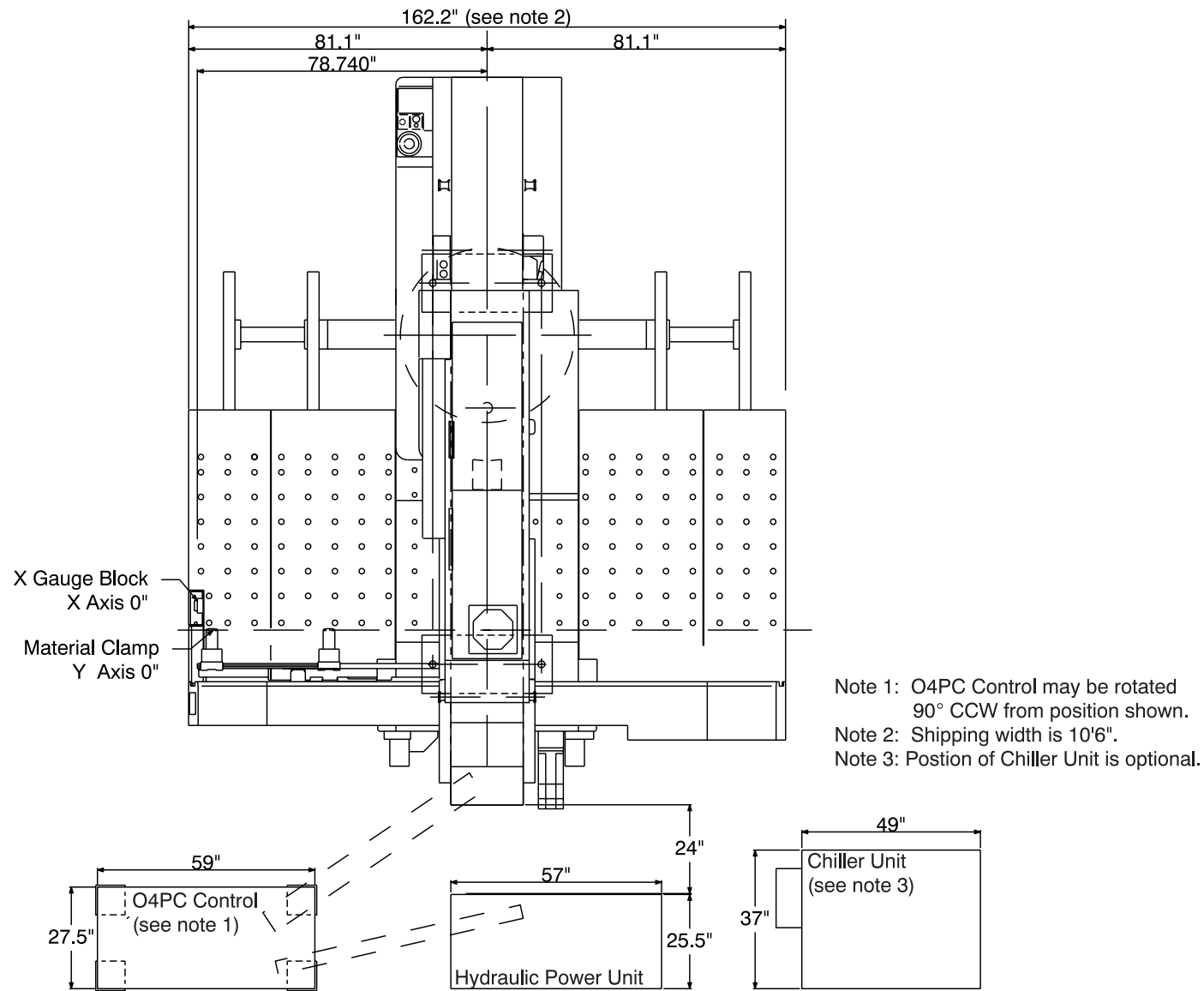

Machine Dimensions - Elevation View

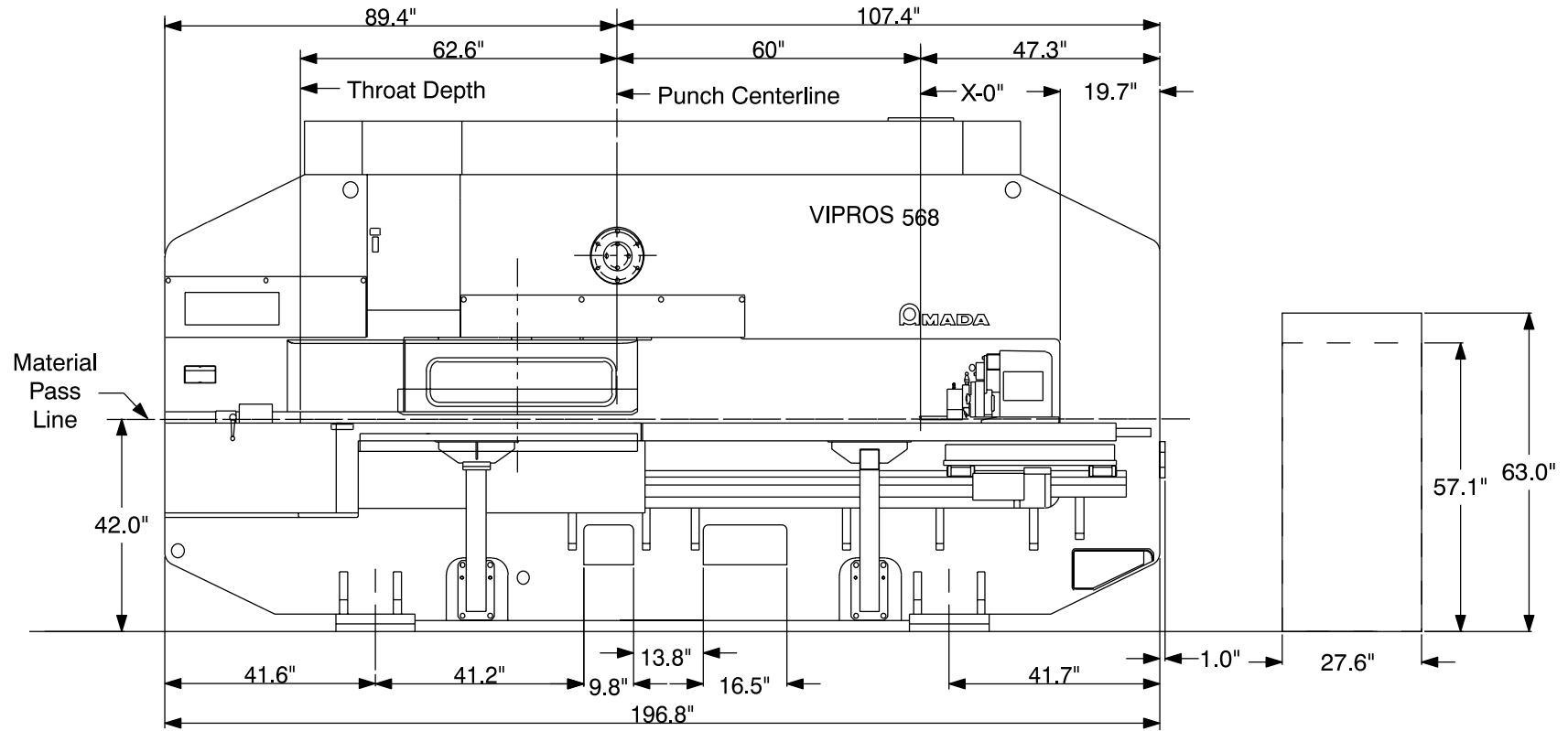

Machine Dimensions - End View

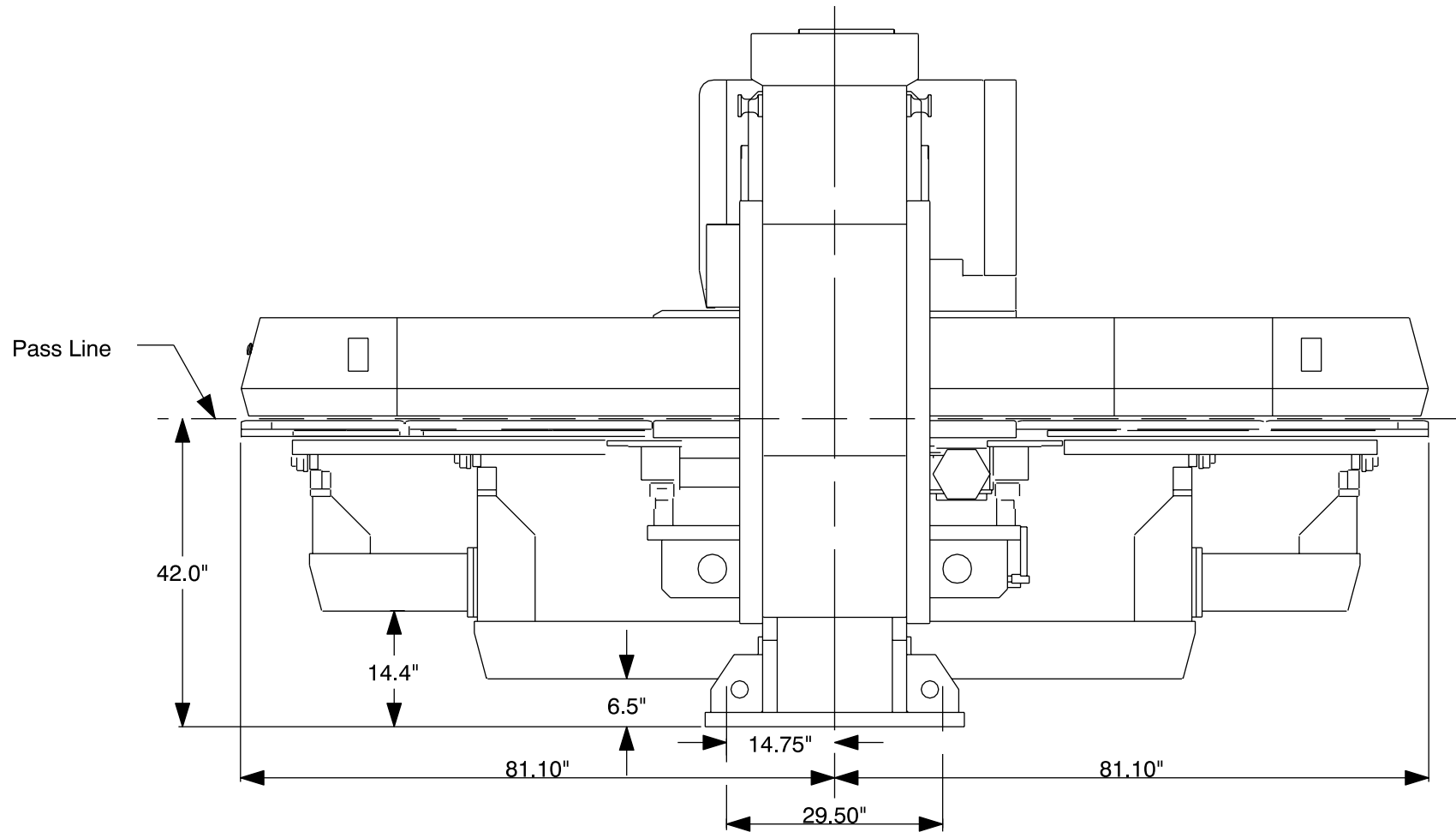

Maintenance Areas

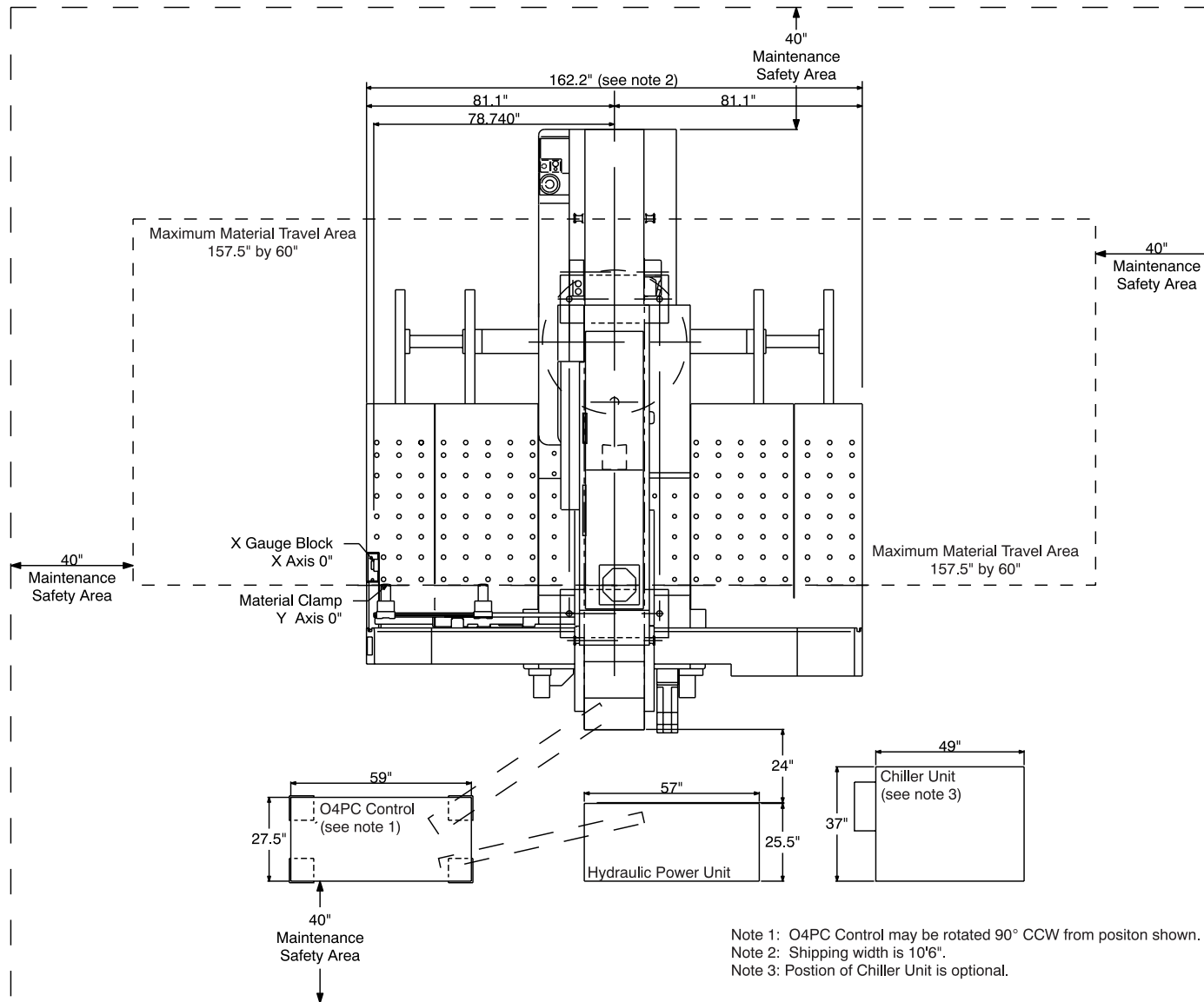

The Chiller

Chiller Cautions

The Chiller Unit is very important to the reliable operation of the Vipros 568.

- The Chiller must be placed so that an adequate flow of air is maintained.
- The position of the Chiller is flexible. The Vipros 568 is supplied with two (2) fifteen-foot lengths of hose to connect the Chiller to the Hydraulic Unit. The customer may supply a longer length of hose if required.
- Under normal operating conditions the Chiller may be placed against walls as shown. However for maintenance purposes access to all sides of the Chiller may be required.
- The Chiller must have a minimum of 60" of clearance above the Chiller for proper airflow.

Chiller Placement

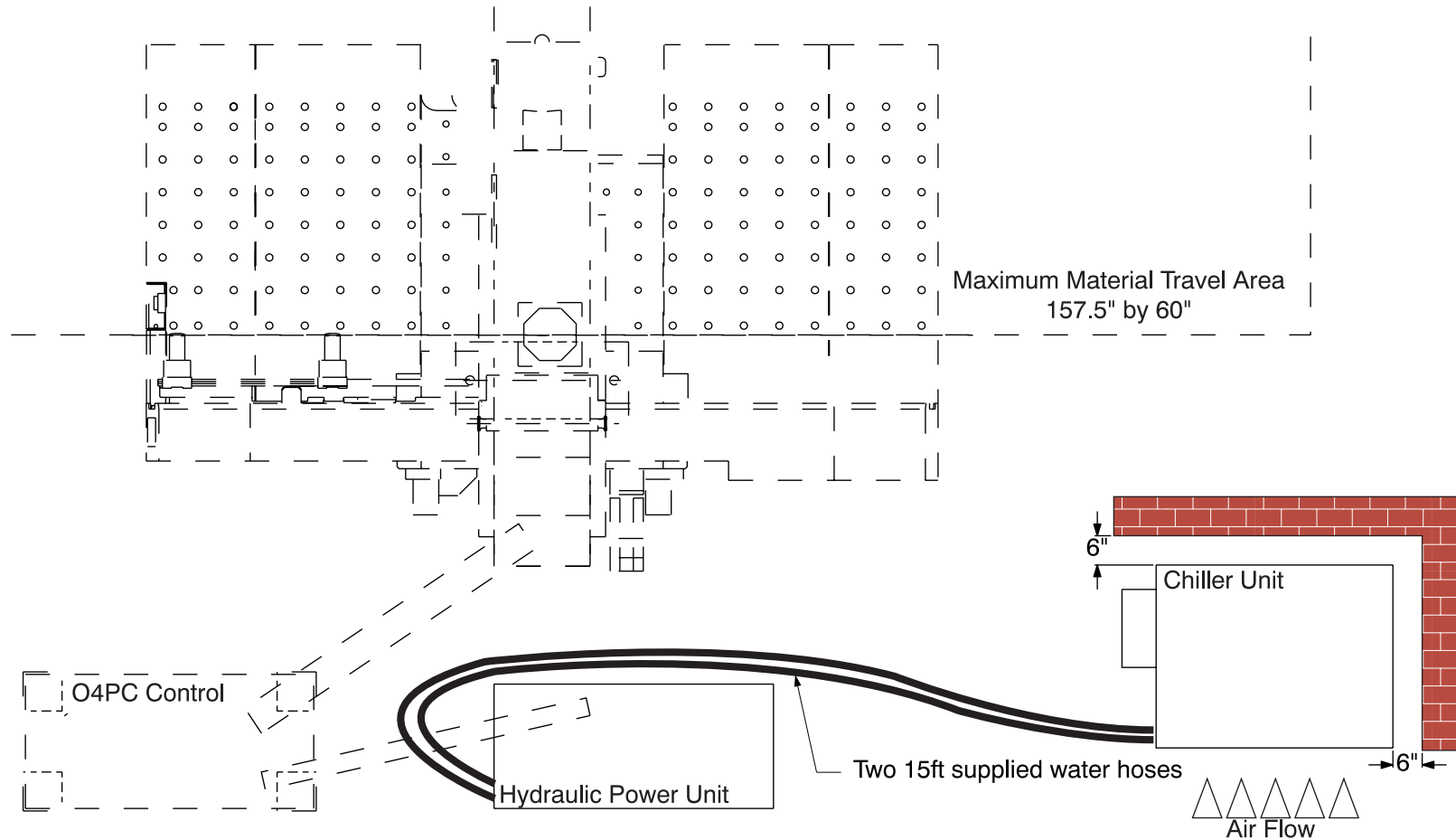

Under normal operating conditions the Chiller may be placed against walls as shown. For maintenance purposes access to all sides may be required. 60" overhead clearance required. Chiller may be located up to 50ft from Hydraulic Unit. Chiller is not designed for outdoor placement.

Connections

Chiller

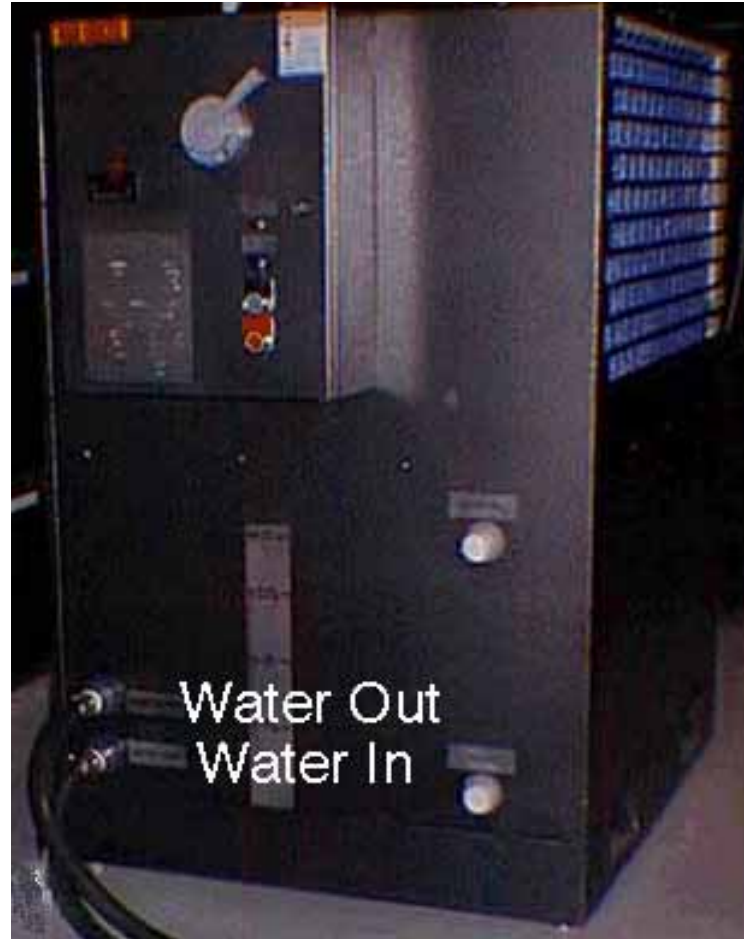

Hydraulic Unit

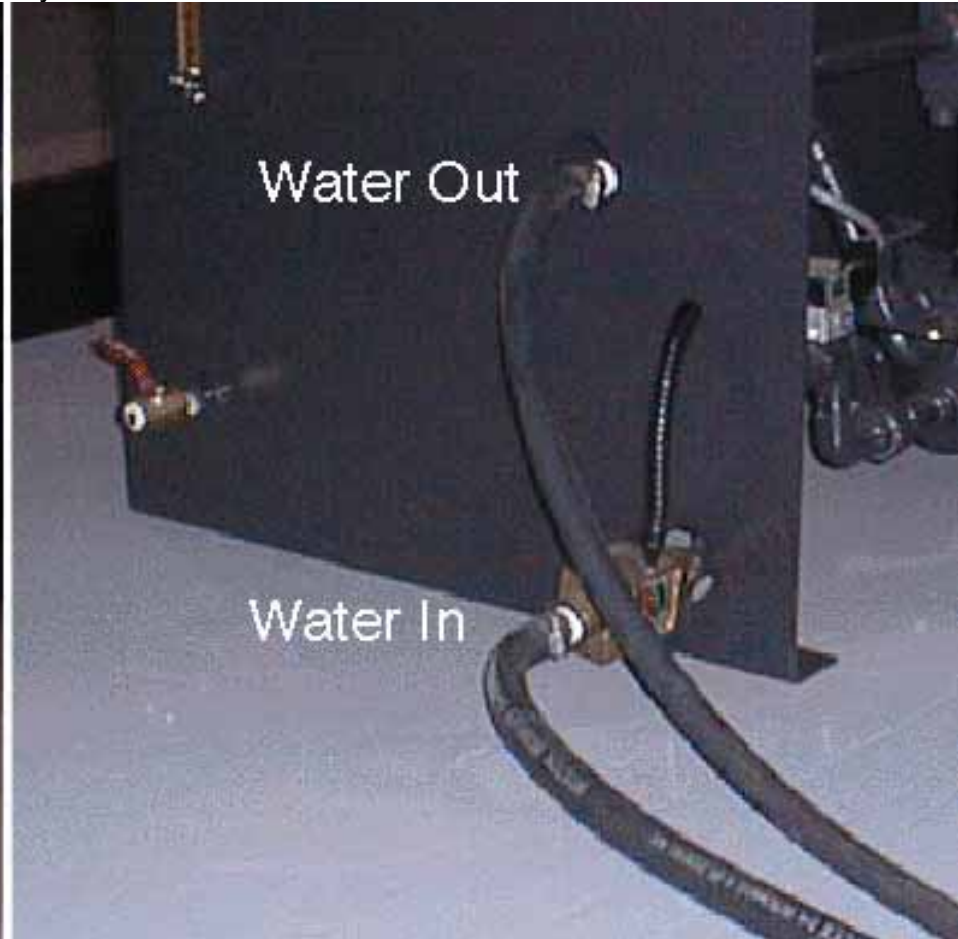

Foundation Requirements

The Vipros 568 does not require a special foundation to perform as expected, however there are minimum requirements that an existing floor must meet in order to assure machine reliability and tool life. If the existing floor does not meet the following minimum requirements, plans for a recommended foundation are given in the section *Foundation Mounting Procedure*

The minimum acceptable floor conditions to assure a successful installation are:

- The area of the floor where the machine frame is to be located must be a single, homogeneous slab in good condition. There must be no cracks or other signs of deterioration of the floor.
- The floor must be 4" to 6" thick.
- The floor must be capable of supporting 3.5 tons/ft².
- The floor must be level to 0.032"/ft.

If the existing floor meets the minimum requirement list above, it must still be inspected carefully when the anchor-bolt holes are cut. Voids under the floor, or wetness (not associated with the hole cutting procedure) should be considered signs of an inadequate floor and a new machine location or new foundation must be considered.

It is the customer's responsibility to determine that the floor meets these minimum requirements. Placing the machine on an inadequate, cracked floor, or straddling seams in a floor may be grounds for voiding the machine warranty!

Amada America, Inc. does not recommend the use of vibration isolating mounts under the machine feet, as these devices have been shown to increase the vibration within the machine frame, increasing the likelihood of vibration related problems. Solid leveling devices are acceptable provided they incorporate a means of anchoring the machine to the floor with the supplied J-bolts.

Machine Anchoring Requirements

To maintain machine reliability, extend tool life, and remain level over an extended period the Vipros 568 must be anchored in place on an adequate floor or foundation.

At a minimum the floor must consist of a single, homogeneous slab, level to within 0.032"/ft², and capable of supporting 3.5 tons/ft². It is the purchaser's responsibility to determine that the floor meets these minimum requirements.

Floor J-bolt Mounting Hole Detail (saw cut hole)

This machine mounting method should be used only if the floor is of such quality that it will support the weight of the machine with the anchor J-bolts used only for maintaining the location of the machine.

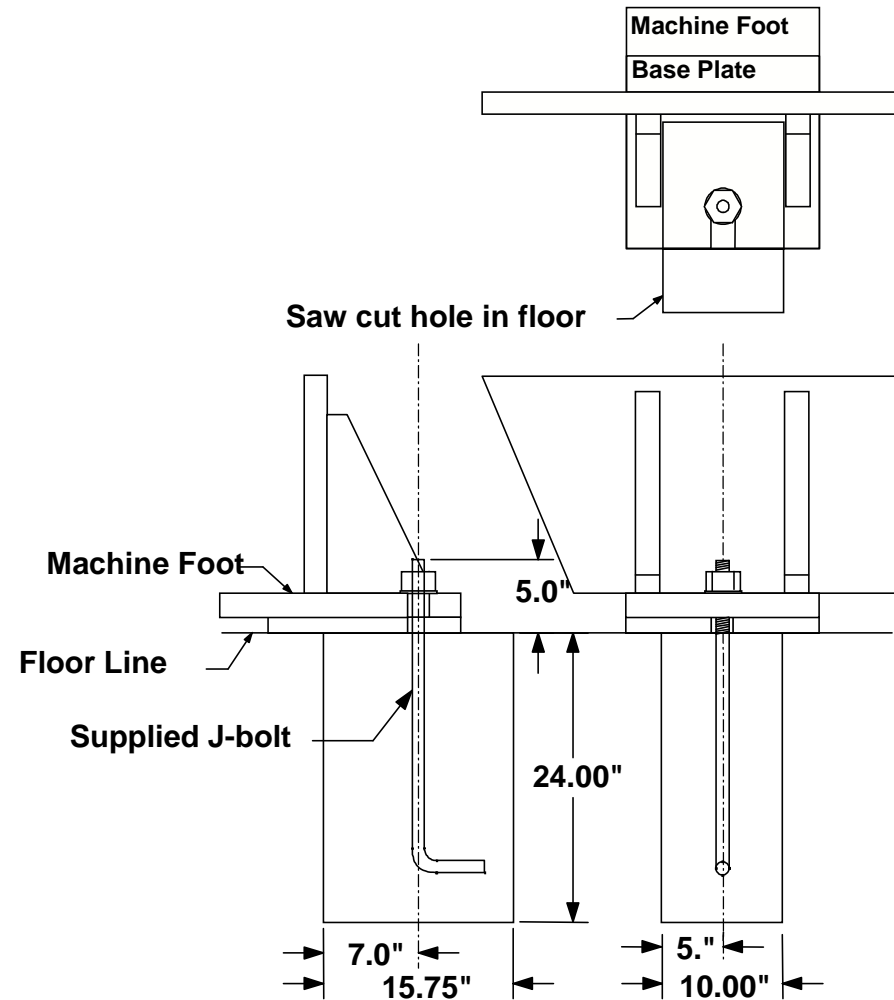

Floor J-bolt Mounting Hole Plan View (saw cut hole)

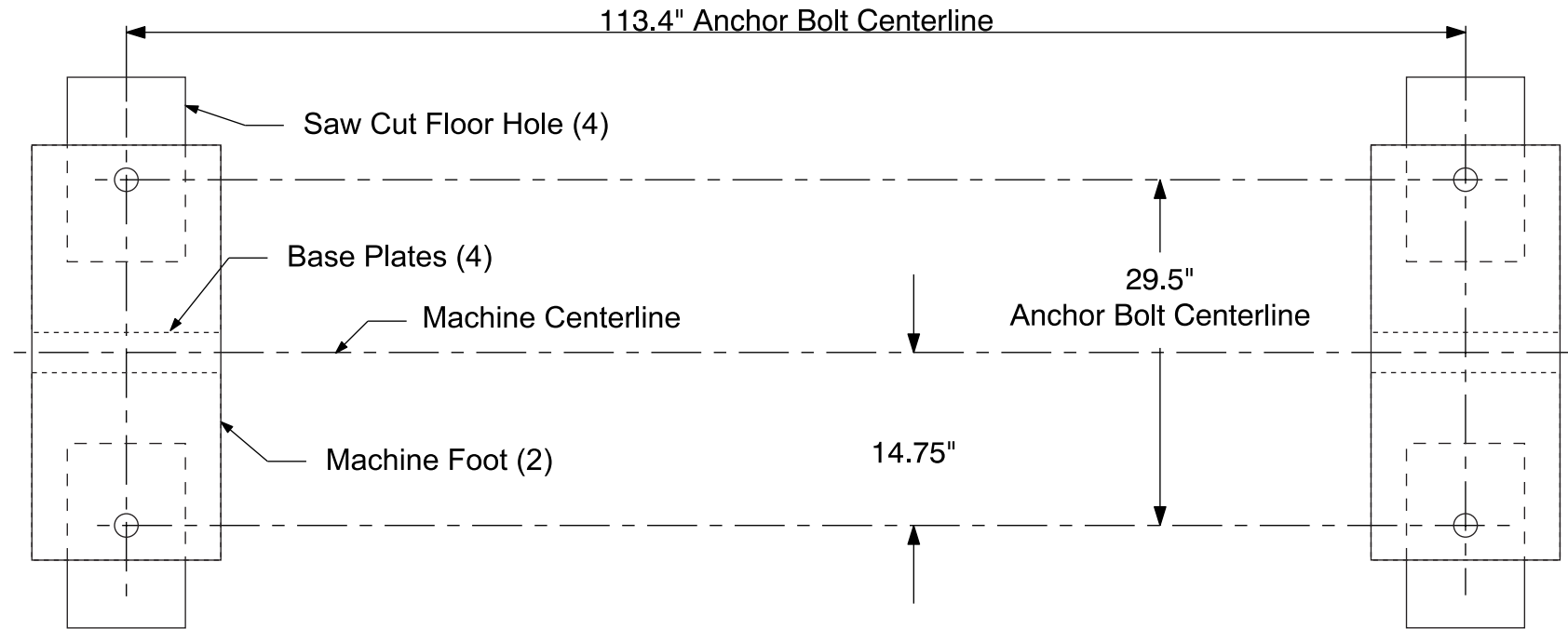

Alternative Floor J-bolt Mounting Hole Detail (Core Drill)

This machine mounting method should only be used if the floor is of such quality that it will support the weight of the machine with the anchor J-bolts used only for maintaining the location of the machine.

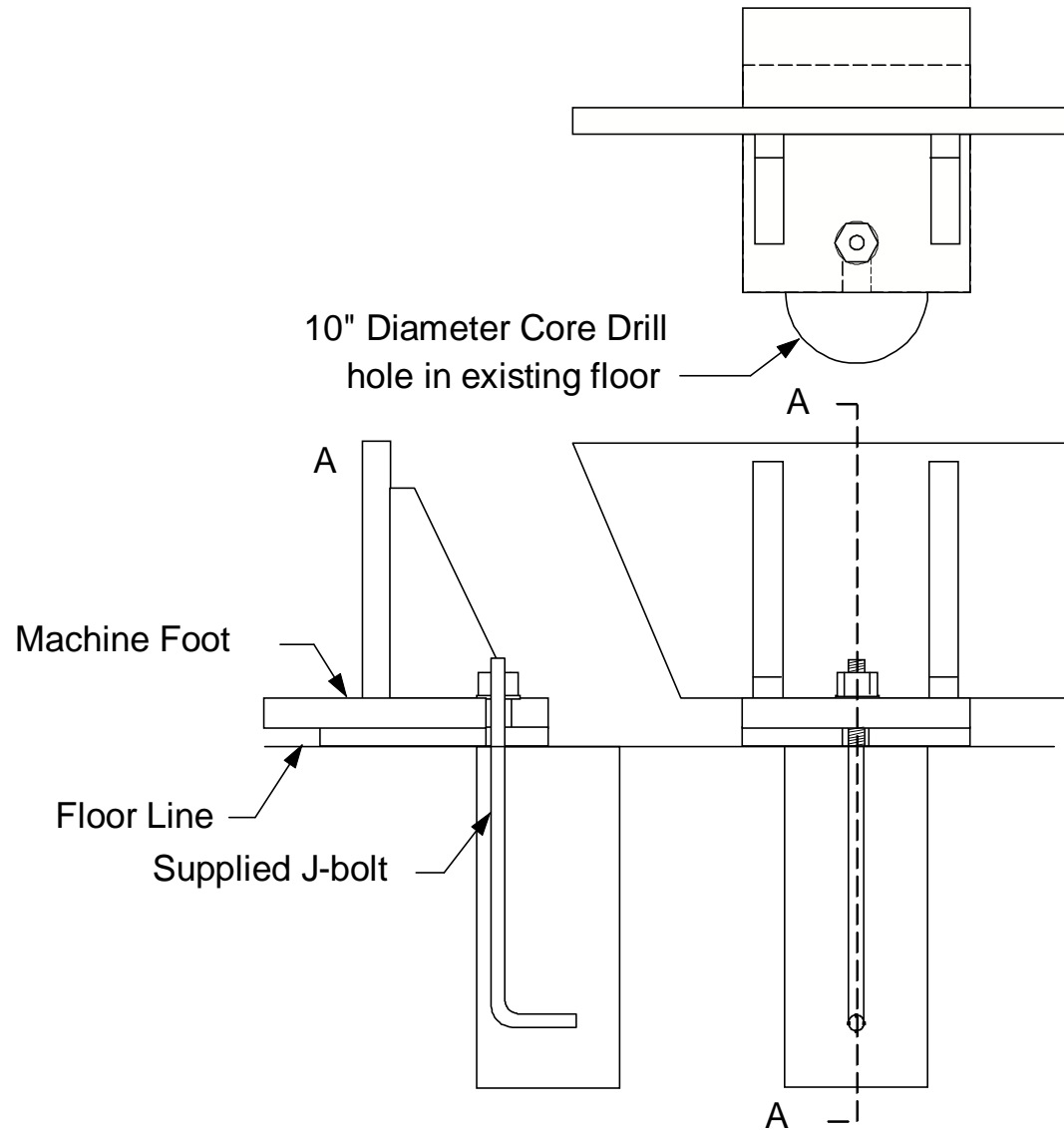

Alternative J-bolt Mounting Method Plan View (Core Drill)

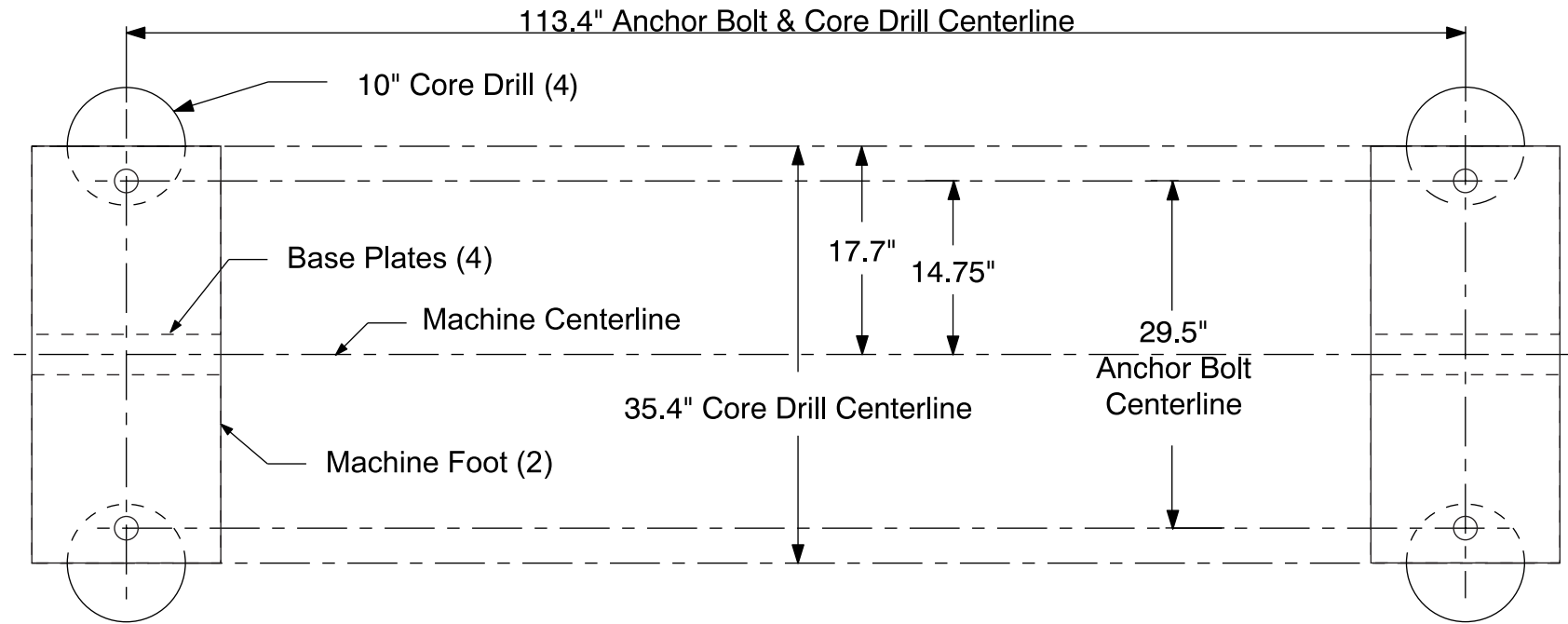

Floor J-bolt Mounting Procedure

- Step 1. Saw cut or Core drill a hole in the existing floor and remove the underlying dirt to the required 24" depth.

See *Floor J-bolt Mounting Hole Plan View (saw cut hole)* or *Alternative J-bolt Mounting Method Plan View (Core Drill)* for correct layout dimensions of the four anchor holes required.

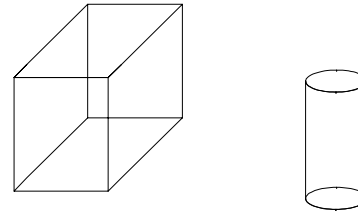

- Step 2. Set base plate over the hole.

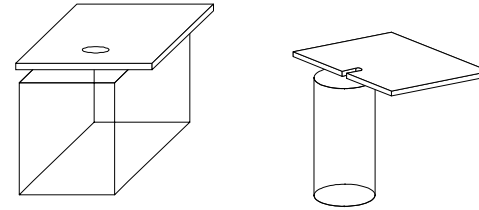

- Step 3. Set the machine on the base plate.

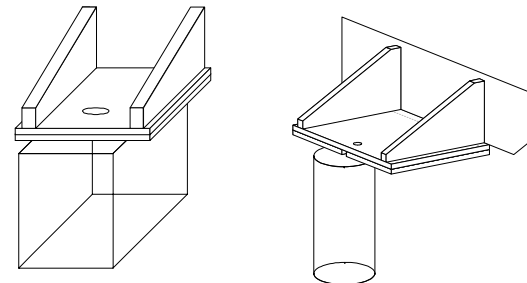

- Step 4. Set the J-bolt through the hole in machine foot; attach washer and nut to hold J-bolt in place.

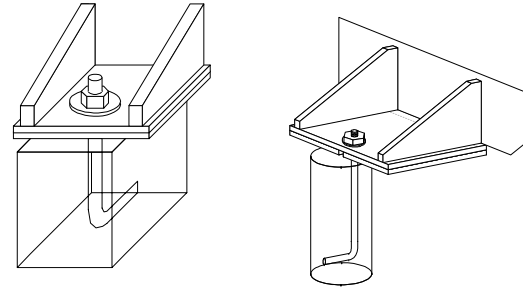

- Step 5 Pour the Concrete.
Ensure that the J-bolt remains correctly aligned to the machine frame during the pouring and hardening time of the concrete.
Ensure that the concrete level is equal to the floor level

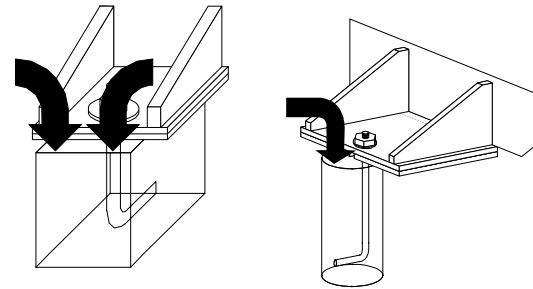

- Step 6. To complete the mounting procedure, level the machine frame by inserting leveling shims between the machine foot and base plate.

See *Leveling the Machine* section for correct procedure.

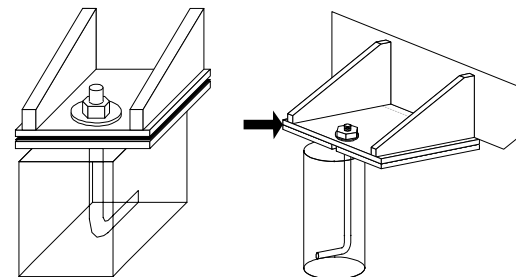

Foundation Mounting Procedure

An ideal foundation is given on the following pages. This foundation must be used if the existing floor cannot meet the minimum requirements to support the machine.

The foundation must consist of a single, homogeneous slab. The foundation must be level to within 0.032" / ft. Anchoring the Vipros 568 to the floor using the anchor-bolts supplied is essential to ensure reliable performance. Amada generally recommends that the foundation have a minimum load bearing capacity of 3.5 ton/ft². It is the purchaser's responsibility to determine that the foundation meets these requirements.

Please note the following:

- The base plates, shims, anchor bolts, nuts, and washers are shipped with the Vipros 568.
- The concrete J-bolt pads should be filled after the machine is placed on the foundation.

Foundation J-bolt Detail

See *J-bolt Mounting Procedure* for proper method of mounting machine on foundation.

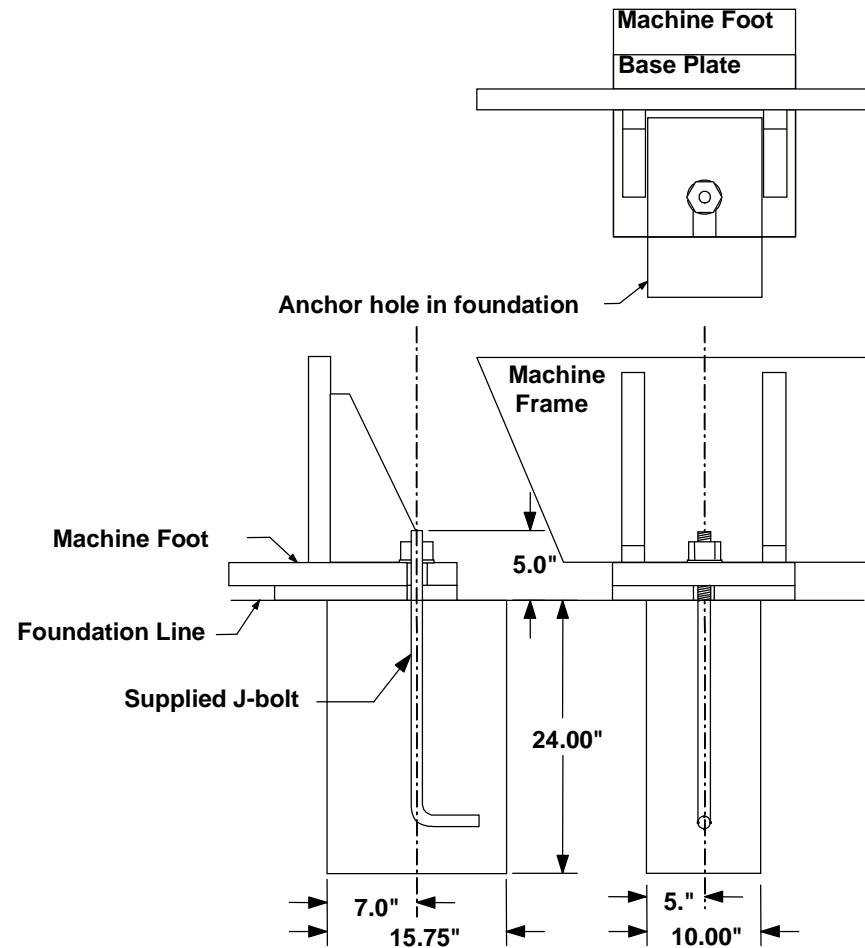

Foundation Plan View

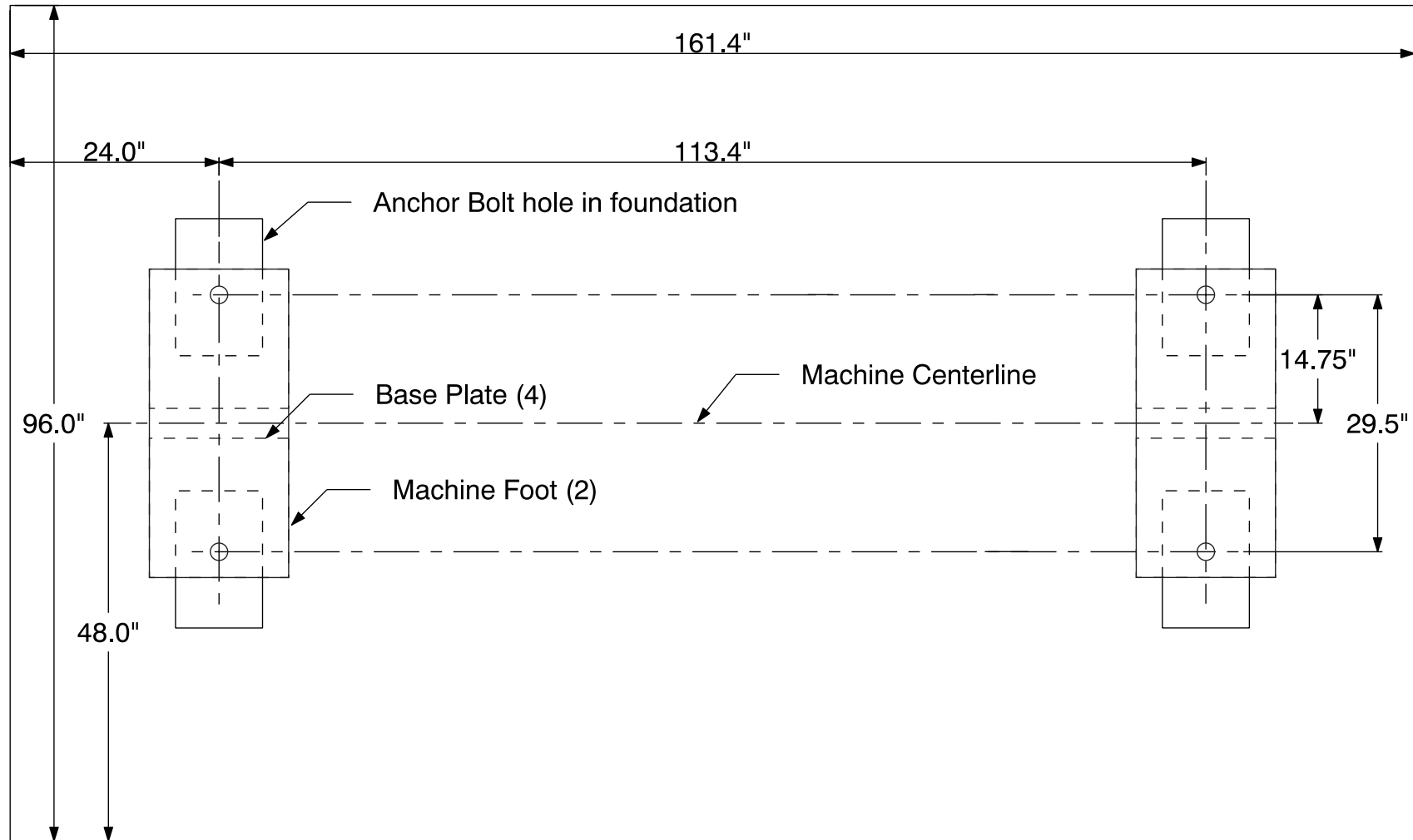

Foundation Elevation View

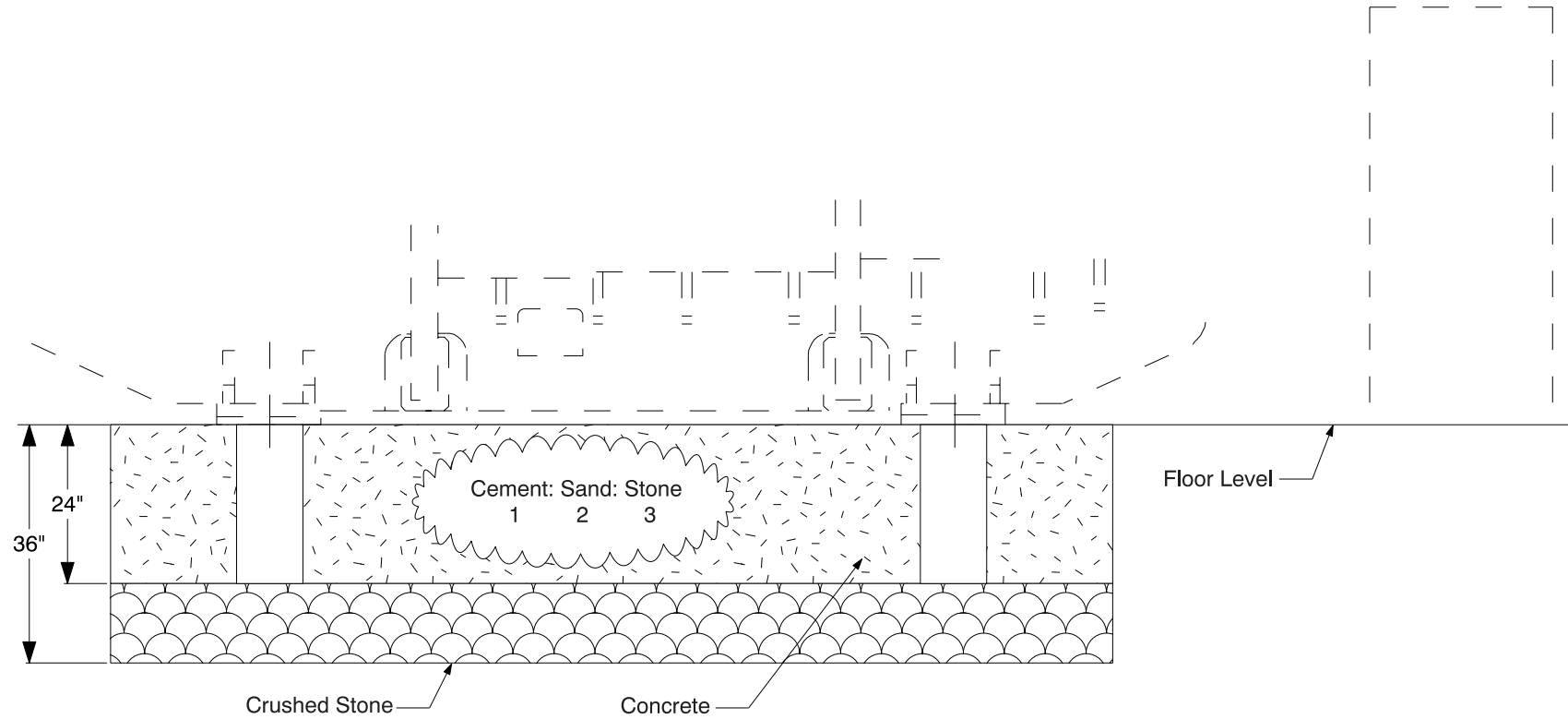

Removing the Protective Coating

The Vipros 568 must be thoroughly cleaned of protective coating. The sheet metal guards can be removed from around the turret to allow cleaning of the upper and lower turrets, tool bores and die holders.

Please note the following:

- Remove the wrapping paper from the X and Y-axes ball screws then remove the protective coating.
- Remove the wrapping paper from the X and Y LM guides then remove the protective coating, make sure that you remove the paper from both sides of the carriage.
- Clean die holders one at a time. Remove a die holder, clean and replace it before removing the next die holder. If the die holders are mixed up, serious turret alignment problems may occur.
- A suitable solvent should be used to remove the protective coating.

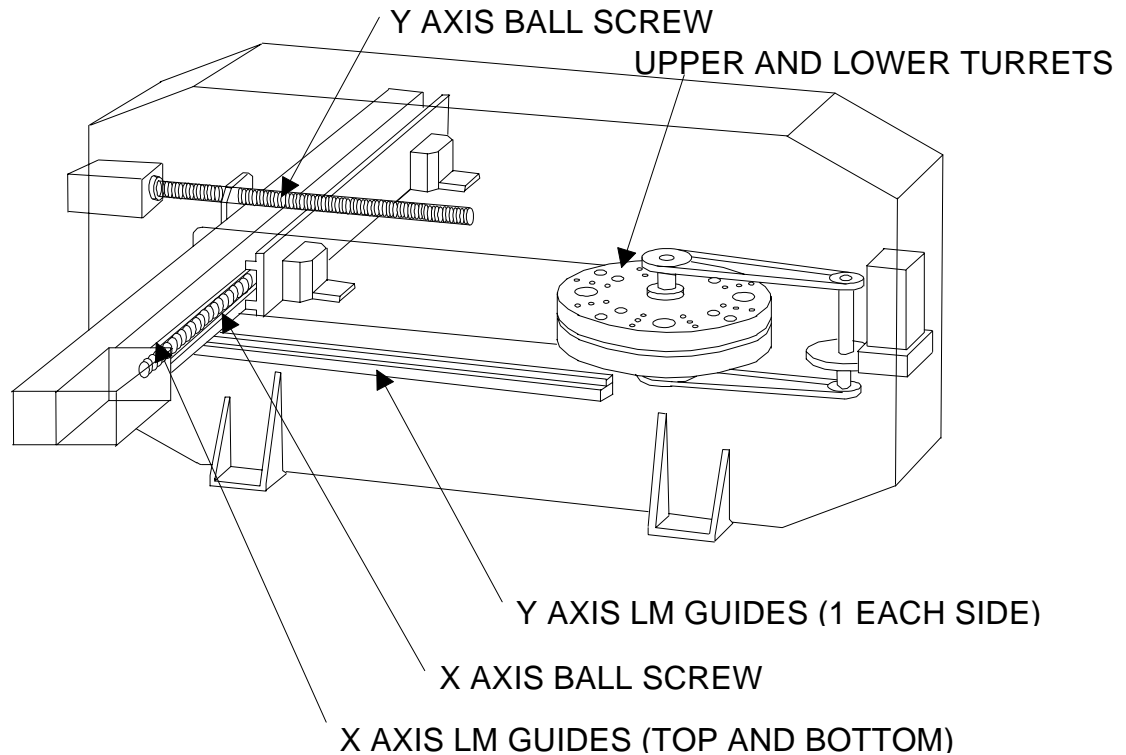

Machine Leveling

Proper Machine leveling is critical to the Vipros 568 performing as designed.

Materials and tools required:

Supplied with the machine:

Assorted thickness machine leveling shim stock

Anchor bolts

Supplied by AESI service:

Spirit level capable of reading 0.0005"/ft

One (1) 12 ton hydraulic bottle jack

Not supplied:

Additional shim stock of 0.005" thickness may be required to achieve a properly leveled machine.

Rocking Test

After the machine frame has been leveled the use of the following G-code is necessary to determine that the machine frame is properly leveled and balanced.

Should the machine frame vibrate or move excessively during the rocking test the machine frame must be re-leveled using the procedure in this manual.

Should the proper leveling technique not eliminate the excessive frame motion, consideration must be given to relocation of the machine or replacement of the existing floor with an adequate foundation.

Set M500 values to Top Position 0.080", Bottom Position, 0.080", Slow Position 0.000"

Repeat test with X-axis movement values of 0.500", 1.000", and 4.000"

G92X78.740Y60.000

G06A.100B0

M500

N1

G91X-.250TTTT (Use any valid tool number)

X.250

M97P1

G50

Floor Condition: Crowning

The flatness of the floor plays an important step in the leveling procedure of the machine. To properly level the machine the weight bearing points must be as far from the centerline of the machine frame as possible.

Should a condition known as crowning exist the weight bearing points of the machine may not be far enough from the machine centerline to ensure a stable machine.

Under these conditions a procedure known as *Half-Shimming* should be used.

To move the weight bearing points further from the machine centerline the use of half-shims of .125" thick on top of the base plate as shown is recommended.

After the half-shims are installed and the machine frame is leveled use the rocking test to determine that the machine frame is stable enough to allow production without damaging the machine.

Under extreme conditions the use of half-shims may not move the machine weight bearing points far enough from the machine centerline to ensure the machine frame is stable.

Under these conditions a more suitable location must be found for the machine, or a new foundation for the machine will be necessary.

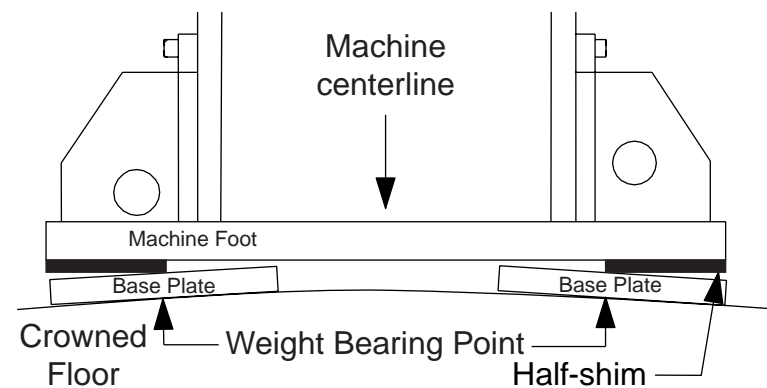
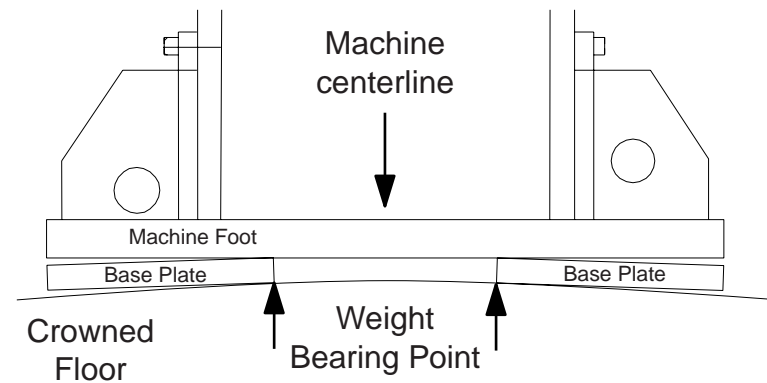

Floor Condition: Slope

The slope of the floor plays an important step in the leveling procedure of the machine. To properly level the machine the weight bearing points must be as far from the centerline of the machine frame as possible.

Should the floor slope excessively the weight bearing points of the machine may not be far enough from the machine centerline to ensure a stable machine.

Under these conditions a procedure known as *Half-Shimming* should be used.

To move the weight bearing points further from the machine centerline the use of half-shims of .125" thick on top of the base plate and leveling shims as shown is recommended.

After the half-shims are installed and the machine frame is leveled, use the rocking test to determine that the machine frame is stable enough to allow production without damaging the machine.

Under extreme conditions the use of half-shims may not move the machine weight bearing points far enough from the machine centerline to ensure the machine frame is stable.

Under these conditions a more suitable location must be found for the machine, or a new foundation for the machine will be necessary.

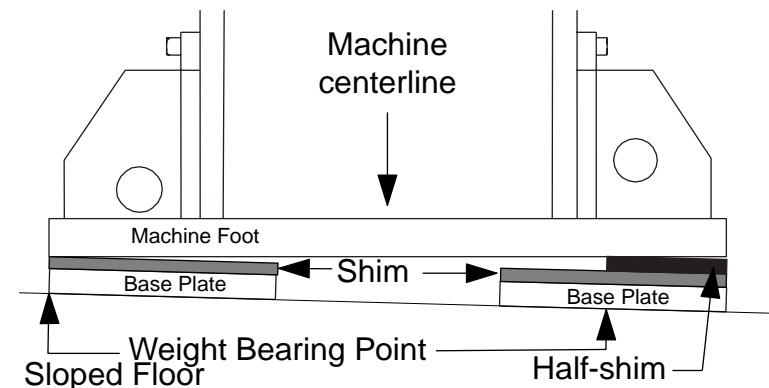
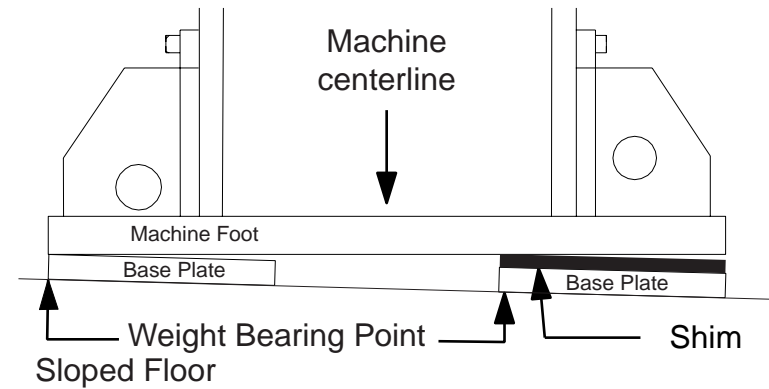

Leveling Procedure

- 1) Determine the high end of machine frame by placing the spirit level on the turret to measure the level of the machine frame in the y-axis.
- 2) Use the bottle jack to lift the low end of the machine frame.
- 3) Shim equally between both machine feet and the base plates until the machine frame measures near level on the y-axis with the turret end of the machine frame slightly higher than the carriage end.
- 4) Center the bottle jack under the carriage end of the machine frame.
- 5) Lift the machine frame until all weight is off of the machine feet at the carriage end of the machine frame.
- 6) Lift the machine frame as little as possible to take the weight off of the base plates.

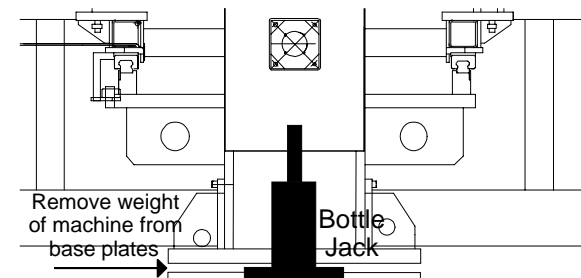
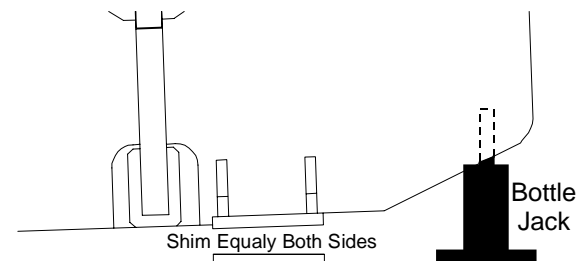
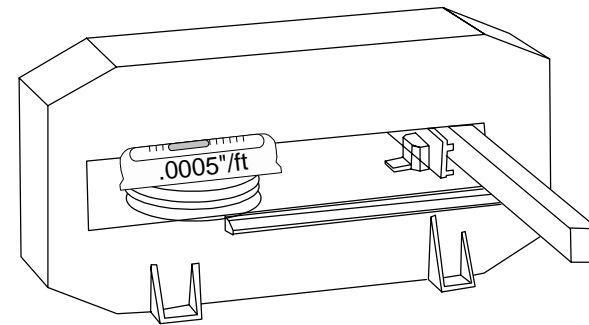

- 7) With the machine supported on the bottle jack at the carriage end of the machine frame and the machine feet at the turret end of the machine frame, place the spirit level on the turret.
- 8) Measure and record the level of the turret in the x-axis direction.
- 9) Lower the machine frame to place all machine feet in contact with the leveling shims and base plates.
- 10) Lift the turret end of the machine frame to allow shimming between the machine feet and base plates to level the machine frame in the x-axis direction.
- 11) Repeat steps 3 to 5 until the machine frame measures level to 0.0005"/ft in step 4, then continue.
- 12) With the bottle jack supporting the weight of the carriage end of the machine monitor the level of the turret in the x-axis as the bottle jack is slowly lowered to place the carriage end machine feet in contact with the base plates.
- 13) Any change in the level indicates that the carriage end of the machine needs to be leveled.

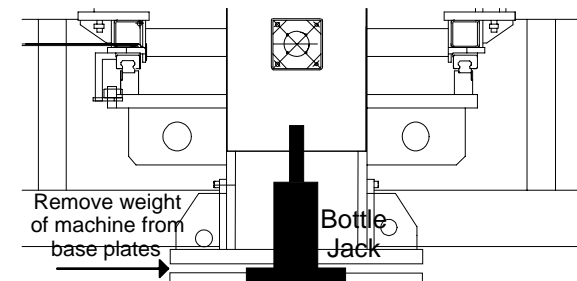
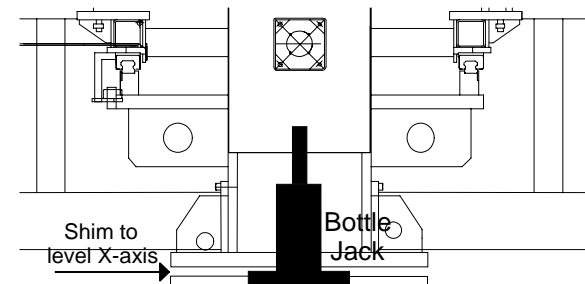
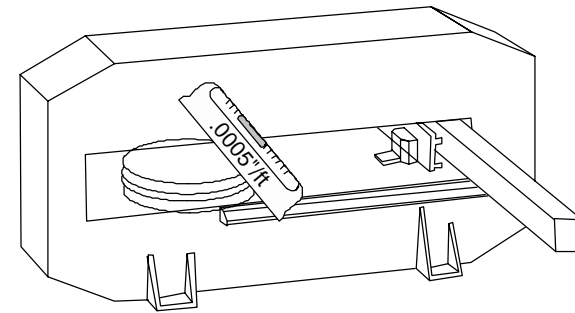

- 14) Lift the carriage end of the machine frame to allow shimming between the machine feet and base plates to level the carriage end of the machine frame in the x-axis direction.
- 15) Repeat steps 6 and 7 until no difference in level is noted when the machine weight is on or off of the base plates and shims, then continue.
- 16) With all of the machine feet setting on the shims and base plates place the spirit level on the turret to measure and note the level of the machine frame in the y-axis.
- 17) Using the bottle jack lift the low end of the machine frame and shim equally under both machine feet to level the machine frame in the y-axis.
- 18) Repeat steps 8 to 9 until the machine frame measures level to 0.0005"/ft in the y-axis, then continue.
- 19) Run the machine using the rocking test G-code to determine that the machine frame is leveled adequately. Should excessive movement of the machine frame be noticed check for the conditions discussed in *Floor Condition Crowning* and *Floor Condition Slope*.

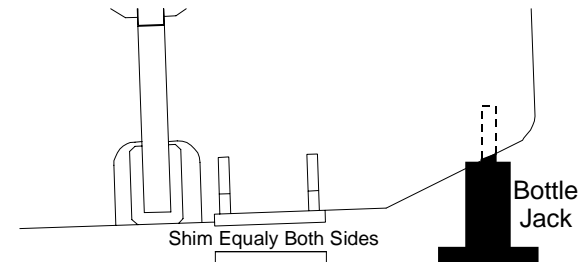
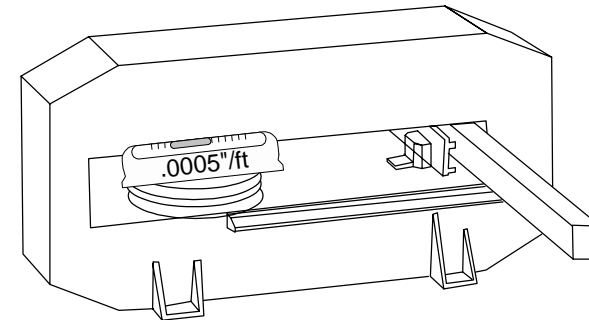
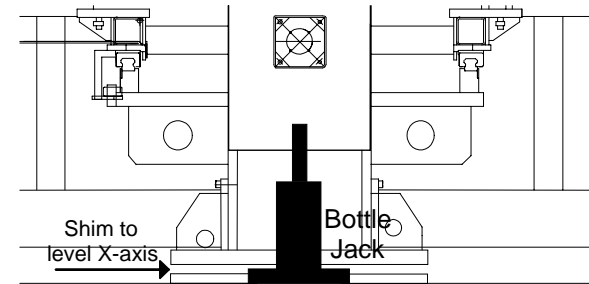

- 20) Tighten the anchor bolt nuts to prevent the machine frame from moving when in use. Monitor the machine level while tightening the anchor bolts to assure the machine level is not changed.

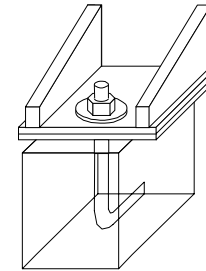

- 21) Lower and lock the outrigger weight support feet in place.