

Coma 567 with Fanuc 04PC User Pre-installation Guide



LAPIS SERVICES
(219) 464-9131

Amada Support,
Rebuilds, Sales And
Fanuc Control Upgrades.

Amada America Inc.
7025 Firestone Blvd.
Buena Park CA. 90621
Phone: (714) 739 2111
Fax.: (714) 739 4099
Email info@amada.com



LAPISINC.COM

Warning

- ❑ Qualified personnel must complete all work.
- ❑ Do not apply power to the Coma 567 until an A.E.S.I. (Amada Engineering and Service Incorporated) Engineer is present and has instructed you to do so.
- ❑ Considerable effort has been made to ensure that this manual is free of inaccuracies and omissions. However, as we are constantly improving our product, some of the data contained herein may not exactly reflect the latest revisions to the Coma 567. If in doubt concerning a specific item, please contact your local Amada America sales person for clarification, or check our Internet site, <http://www.amada.com> for the latest release of this document.



LAPIS SERVICES
(219) 464-9131

Amada Support,
Rebuilds, Sales And
Fanuc Control Upgrades.

LAPISINC.COM

Contents

- Introduction.....5
- Specifications - Motion Package6
- Specifications - Punching System6
 - Turret Configuration - 44 Station - 2 Auto-Index7
 - Turret Configuration - 58 Station - 2 Auto-Index8
- Specifications - Fanuc 04PC Controller.....9
- Supply Requirements - Electrical10
 - Optional Equipment.....10
 - Installing the Electrical Power Supply11
- Supply Requirements - Pneumatic12
 - Optional Equipment.....12
 - Installing the Pneumatic Supply12
- Planning the Location of the Coma 56713
 - Moving the Coma 56713
 - Plan View - Coma 56714
 - Plan View - Coma 567 Maintenance Area15
 - Elevation View - Coma 56716
 - End View - Coma 56717
- Foundation Requirements18
- Foundation Anchoring Procedure.....19
 - Foundation J-bolt Detail19
 - Plan View - Foundation Coma 56720
 - Elevation - Foundation Coma 567.....20
- Machine Anchoring Requirements Coma 567.....21
 - Floor J-bolt Mounting Hole Detail (saw cut hole).....21
 - Plan - Floor J-bolt Mounting Hole (saw cut hole)21
 - Alternative Floor J-bolt Mounting Hole Detail (Core Drill).....22
 - Plan - J-bolt Mounting Hole (Core Drill).....22
 - Foundation / Floor J-bolt Mounting Procedure23
 - Alternative Anchoring Method (Drilled Hole with Anchor Rod and Adhesive)25

LAPIS SERVICES
(219) 464-9131
Amada Support,
Rebuilds, Sales And
Fanuc Control Upgrades.

Plan - J-bolt Mounting Hole (Drilled Hole with Anchor Rod and Adhesive)25
Drilled Hole with Anchor Rod and Adhesive Mounting Procedure26
Removing the Protective Coating28
Machine Leveling.....29
 Rocking Test29
 Floor Condition: Crowned30
 Floor Condition: Sloped.....31
 Leveling Procedure32



LAPIS SERVICES
(219) 464-9131

**Amada Support,
Rebuilds, Sales And
Fanuc Control Upgrades.**

LAPISINC.COM

Introduction

This manual describes the tasks that the purchaser of a Coma 567 must complete before calling A.E.S.I. (Amada Engineering and Service Incorporated) to complete the installation and operator training.

An overview of the preparations is as follows:

- Plan the location of the Coma 567 taking into account the Recommended Safety and Maintenance areas indicated on the plan view. See page 13, *Planning the Location of the Coma 567*.
- Prepare the Coma 567 floor or foundation as required. See page 18, *Foundation Requirements*, for details.
- Uncrate the Coma 567 and place on the foundation, but do not fill the anchor-bolt holes (if used) until after A.E.S.I. completes the initial installation.
- Install the electrical supply. See page 10, *Supply Requirements - Electrical*, for details.
- Install the pneumatic supply. See page 12, *Supply Requirements - Pneumatic*, for details.
- Remove the protective coating from the surface of the Coma 567 See page 28, *Removing the Protective Coating*, for details.
- If additional equipment is to be installed, repeat the previous steps for each piece of additional equipment.

Note: It is the purchaser's responsibility to install any safety devices to ensure the recommended safety area.

Note: Considerable effort has been made to ensure that this manual is free of inaccuracies and omissions. However, as Amada America strives to continually improve our products, some data contained herein may not exactly reflect the latest revisions to the Coma 567. If in doubt concerning a specific item, please contact your local Amada America sales engineer for clarification.



LAPIS SERVICES
(219) 464-9131

Amada Support,
Rebuilds, Sales And
Fanuc Control Upgrades.

LAPISINC.COM

Specifications - Motion Package

Travel Method	X and Y axes work piece movement
Control Method	X, Y, T & C
Drive Motors	Fanuc AC Servo (X, Y, T, C)
Maximum Sheet Size	60" (Y) x 144" (X) with one repositioning cycle. Additional support tables are required for material lengths greater than 72"
Maximum Sheet Thickness	0.375"
Maximum Material Weight	485 lb.
Maximum Axis Travel	72.0" (X) by 60" (Y)
Max. Table Speed (X / Y / Combined)	1,968 IPM / 1,968 IPM / 2,78328 IPM
Punching Accuracy	±0.0059"
Positioning Accuracy	±0.001"
Repeatability	±0.001"

Specifications - Punching System

Press Capacity	55 Tons
Press Stroke	1.259"
Stroke Per Minute	300
Maximum Hit Rate 1" Centers	200
Maximum Hole Diameter	4.500"
Tool Type	Amada Thick Turret
Turret Rotation Speed	30 RPM
Feed Clearance	0.787"

LAPIS SERVICES
(219) 464-9131

Amada Support,
Rebuilds, Sales And
Fanuc Control Upgrades.

LAPISINC.COM

Turret Configuration - 44 Station - 2 Auto-Index

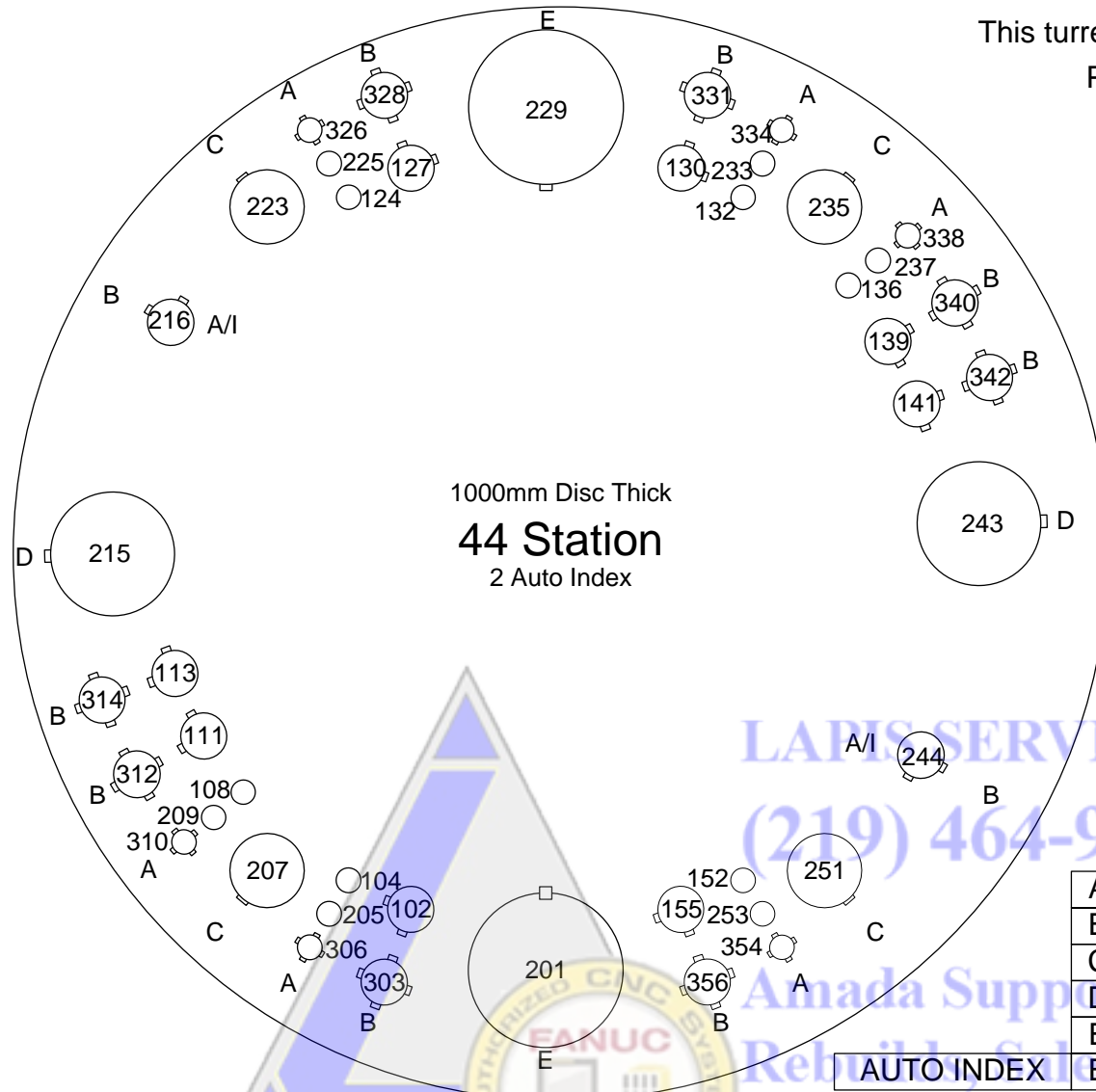

This turret used on the following machine models

Pega 344, 345Q, 345K, 357, 367

Coma 555, 557, 567, 588

Vipros 345, 357, 367

Vela II 355

	MAXIMUM SIZE ROUND		NUMBER OF STATIONS (KEYED)
A	1/2"	12.7mm	18 (6)
B	1 1/4"	31.7mm	16 (16)
C	2"	50.8mm	4 (4)
D	3 1/2"	88.9mm	2 (2)
E	4 1/2"	114.3mm	2 (2)
AUTO INDEX	B	1 1/4"	2 (2)

Turret Configuration - 58 Station - 2 Auto-Index

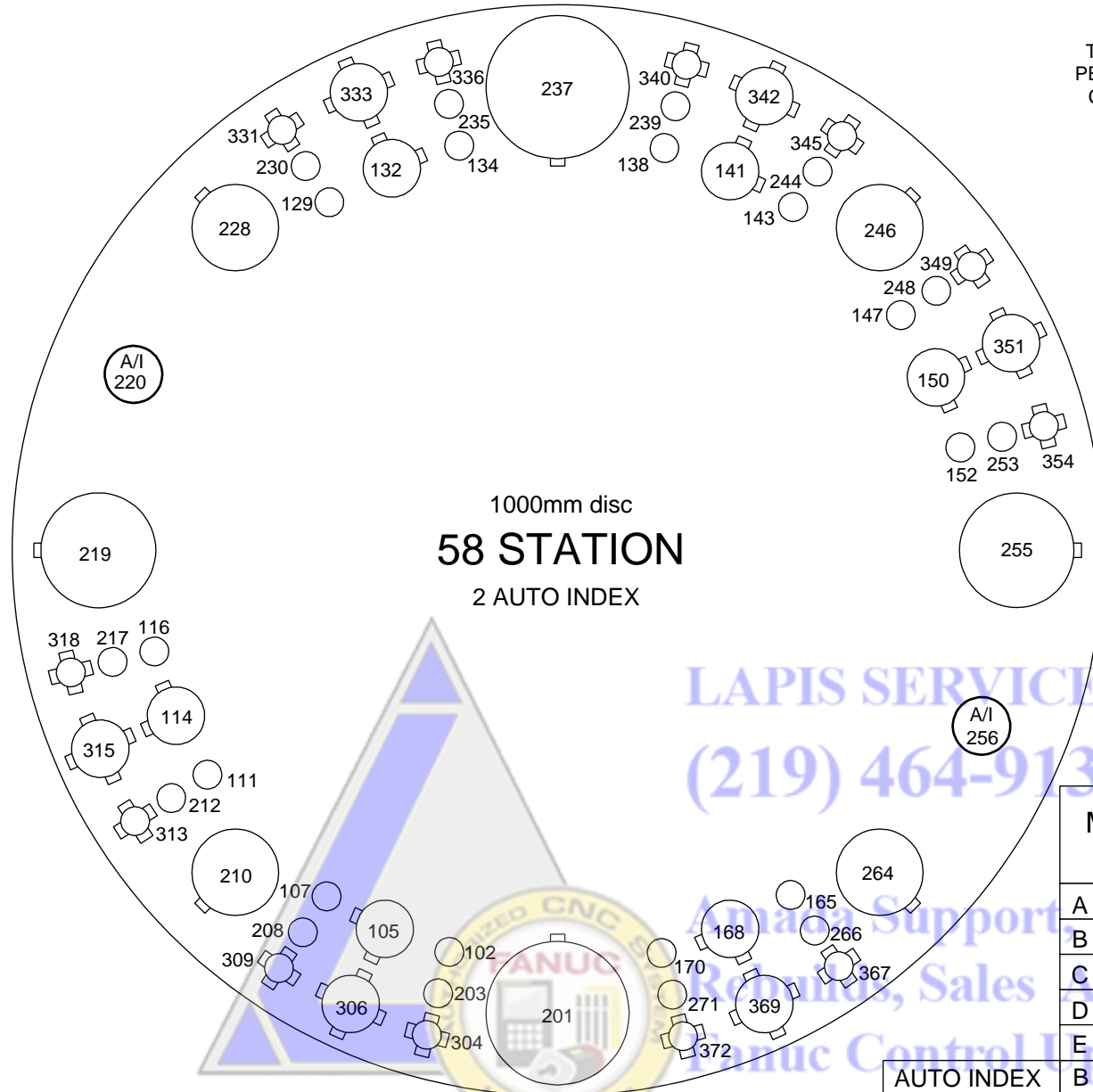

This turret used on the following machine models
 PEGA 345, PEGA 345 King, PEGA 357, PEGA 367
 COMA 555, COMA 557, COMA 567, COMA 588
 VIPROS 345, VIPROS 357, VIPROS 367
 VIPROS 357 Queen, VIPROS 367 Queen

	MAXIMUM SIZE ROUND	NUMBER OF STATIONS (KEYED)
A	1/2" (12.7mm)	36 (12)
B	1 1/4" (31.7mm)	12 (12)
C	2" (50.8mm)	4 (4)
D	3 1/2" (88.9mm)	2 (2)
E	4 1/2" (114.3mm)	2 (2)
AUTO INDEX	B 1 1/4" (31.7mm)	2 (2)

Specifications - Fanuc 04PC Controller

Model	Fanuc 04PC
Control Function	X, Y, T & C
Input Method	MDI, DNC, Paper Tape
Minimum Command Unit	0.001" (X, Y) .01° (C)
Minimum Travel Unit	0.001" (X, Y) .01° (C)
Operating Modes	Automatic, MDI & Manual
Display Modes	Program Contents, Position Information, Program Check, Parameters, Tool Hit Counter, Self Diagnostics
Interlock Displays	Oil Temperature, Oil Pressure, Door Open



LAPIS SERVICES
(219) 464-9131

**Amada Support,
 Rebuilds, Sales And
 Fanuc Control Upgrades.**

LAPISINC.COM

Supply Requirements - Electrical

Coma 567	230 / 460 / 3 / 60 \pm 10%, 18 kVA 46 amps @ 230 / 3 / 60 VAC* 23 amps @ 460 / 3 / 60 VAC*
----------	--

Optional Equipment

Standard Conveyor S1	208 / 230 / 460 3ph \pm 10%, .8 kVA 2.1 amps @ 208 / 3/ 60 VAC* 2.0 amps @ 230/3/60 VAC* 1.0 amps @ 460/3/60 VAC*
Standard Conveyor S2	208 / 230 / 460 3ph \pm 10%, .8 kVA 2.1 amps @ 208 / 3/ 60 VAC* 2.0 amps @ 230/3/60 VAC* 1.0 amps @ 460/3/60 VAC*
C567hs Conveyor	208 / 230 / 460 3ph \pm 10%, .8 kVA 2.1 amps @ 208 / 3/ 60 VAC* 2.0 amps @ 230/3/60 VAC* 1.0 amps @ 460/3/60 VAC*
MP1530 Loader	200 / 3 / 60 \pm 10%, 10 kVA 29 amps @ 200 / 3 / 60 VAC* To operate at 230 / 460 VAC a step up transformer with the following service is required 26 amps @ 230 / 3 / 60 VAC* 13 amps @ 460 / 3 / 60 VAC*

* The actual supplied electrical service must be sized to allow for starting current of approximately 150% of this value.

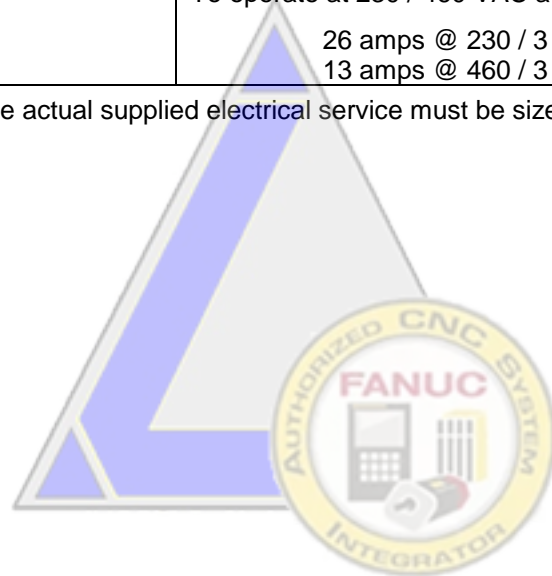

LAPIS SERVICES
(219) 464-9131

Amada Support,
Rebuilds, Sales And
Fanuc Control Upgrades.

LAPISINC.COM

Installing the Electrical Power Supply

The Coma 567 requires one electrical power source. The Coma 567 should be supplied from a power line separate from those for welding machines or other machines that produce electrical noise.

- ❑ The Coma 567 electrical inlet is 64" above floor level at the left side of the Fanuc 04PC control.
- ❑ For the location of required electrical supplies for optional equipment, please see the installation guides for the specific equipment.

Coma 567 left side of electrical enclosure



Coma 567 main power connection inside of electrical enclosure



Supply Requirements - Pneumatic

Coma 567	80 psi @ 8.8 ft ³ /min.
----------	------------------------------------

Optional Equipment

MP1530 Loader	75 psi @ 31.8 ft ³ /min.
---------------	-------------------------------------

Installing the Pneumatic Supply

The Coma 567 requires connection to a compressed air system by hose or pipe. The compressed air must be clean and dry.

Please note the following:

- The minimum pipe inside diameter is ½".
- The air pressure required is 80 psi.
- The air volume required is 8.8 ft³/min..
- The air inlet is approximately 16" above the floor level at the rear of the Coma 567

For the location of required air supplies for optional equipment, please see the installation guides for the specific equipment

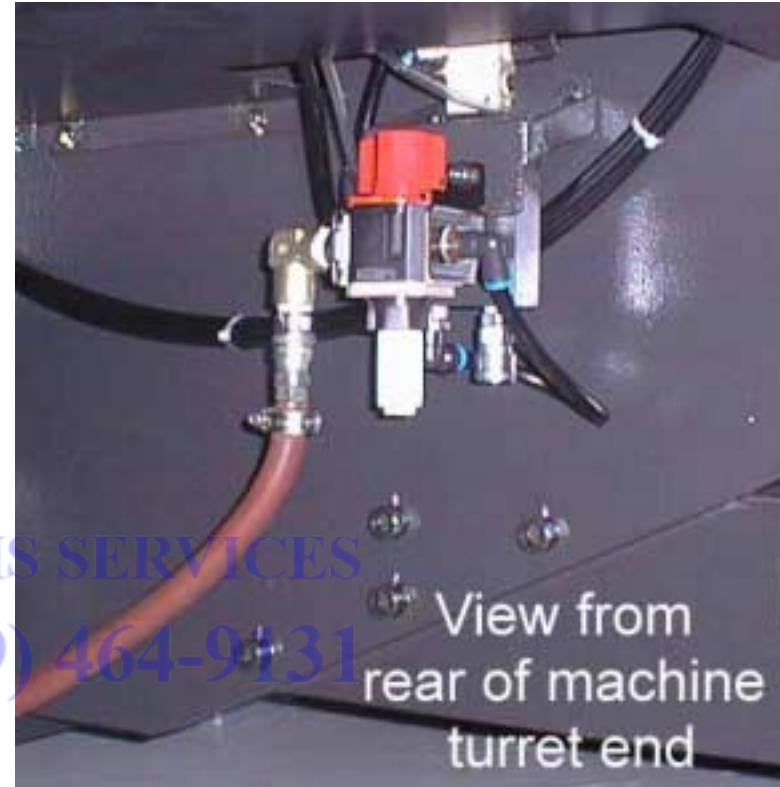

LAPIS SERVICES
(219) 464-9131

Amada Support,
Rebuilds, Sales And
Fanuc Control Upgrades.

LAPISINC.COM

Planning the Location of the Coma 567

The following diagrams provide the details for positioning the Coma 567.

- ❑ No obstacles are allowed in the worksheet travel area and the ceiling must be at least 40" above the Coma 567.
- ❑ All of the Recommended Safety / Maintenance areas should be used, but at a minimum, the doors of the Fanuc 04PC control must be able to be opened. Any reduction of the Recommended Safety / Maintenance areas may decrease personnel safety and increase time and expense of installation and maintenance.
- ❑ The Coma 567 and Fanuc 04PC control must be protected from direct sunlight or other heat sources. Exposure to direct heating sources such as infrared heaters have been shown to affect punch and die alignment.

Moving the Coma 567

Lifting or moving of the Coma 567 should be done only by professional rigging companies well versed in the moving of large and heavy industrial machinery. Acceptable moving methods include, lifting by overhead crane, wheeled dollies beneath the machine feet, or adequately sized liftruck forks beneath the machine frame.

The Coma 567 has a relatively high center of gravity and narrow footprint. Care must be taken to prevent inadvertent tipping of the machine while in motion.

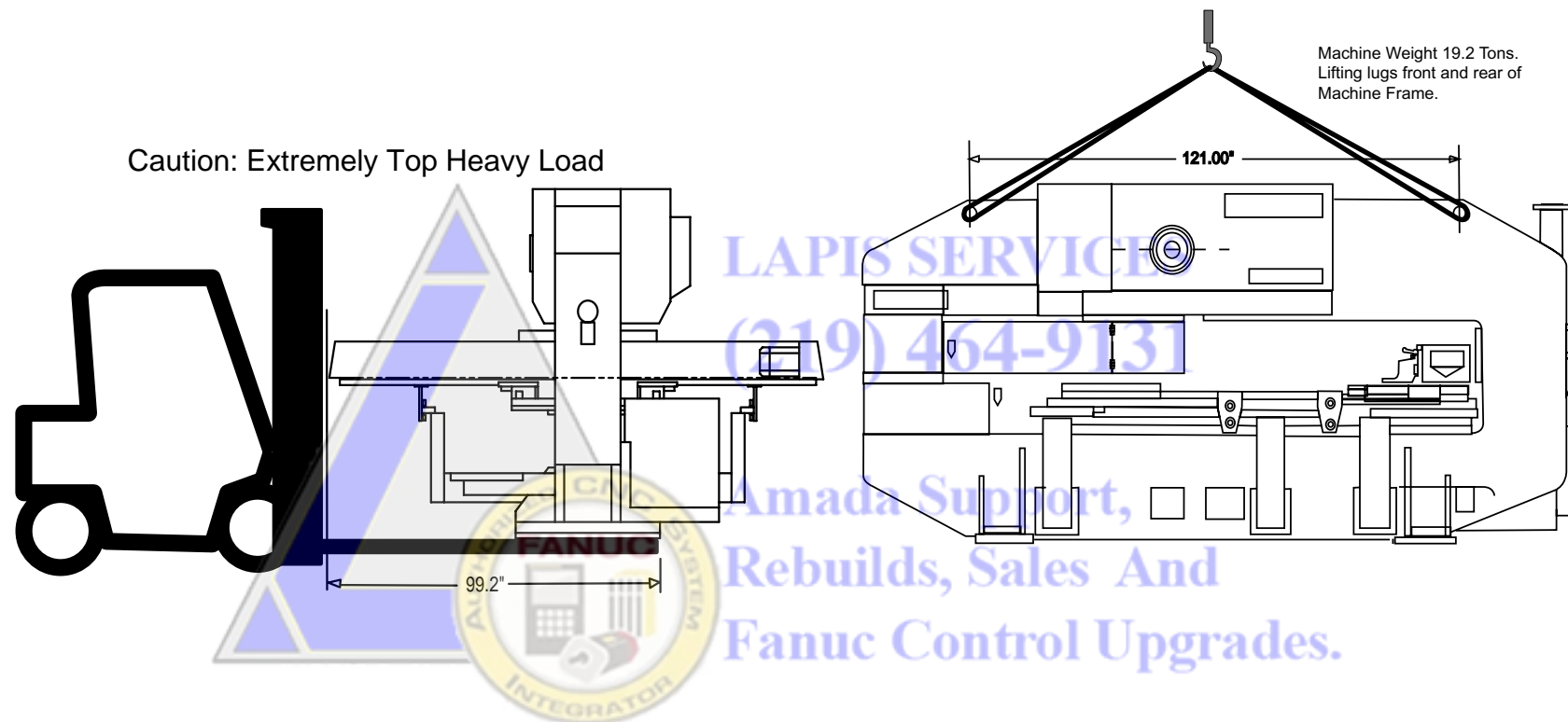

Plan View - Coma 567 Maintenance Areas

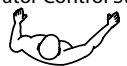
Electrical Requirements	
(E1)	Coma 567 230 / 460 / 3 / 60 ±10% 18 kVA 46 amps @ 230 / 3 / 60 VAC 23 amps @ 460 / 3 / 60 VAC
Compressed Air Requirements	
(A1)	Coma 567 80 psi @ 8.8 ft ³ /min.
Operator Control Station	
	

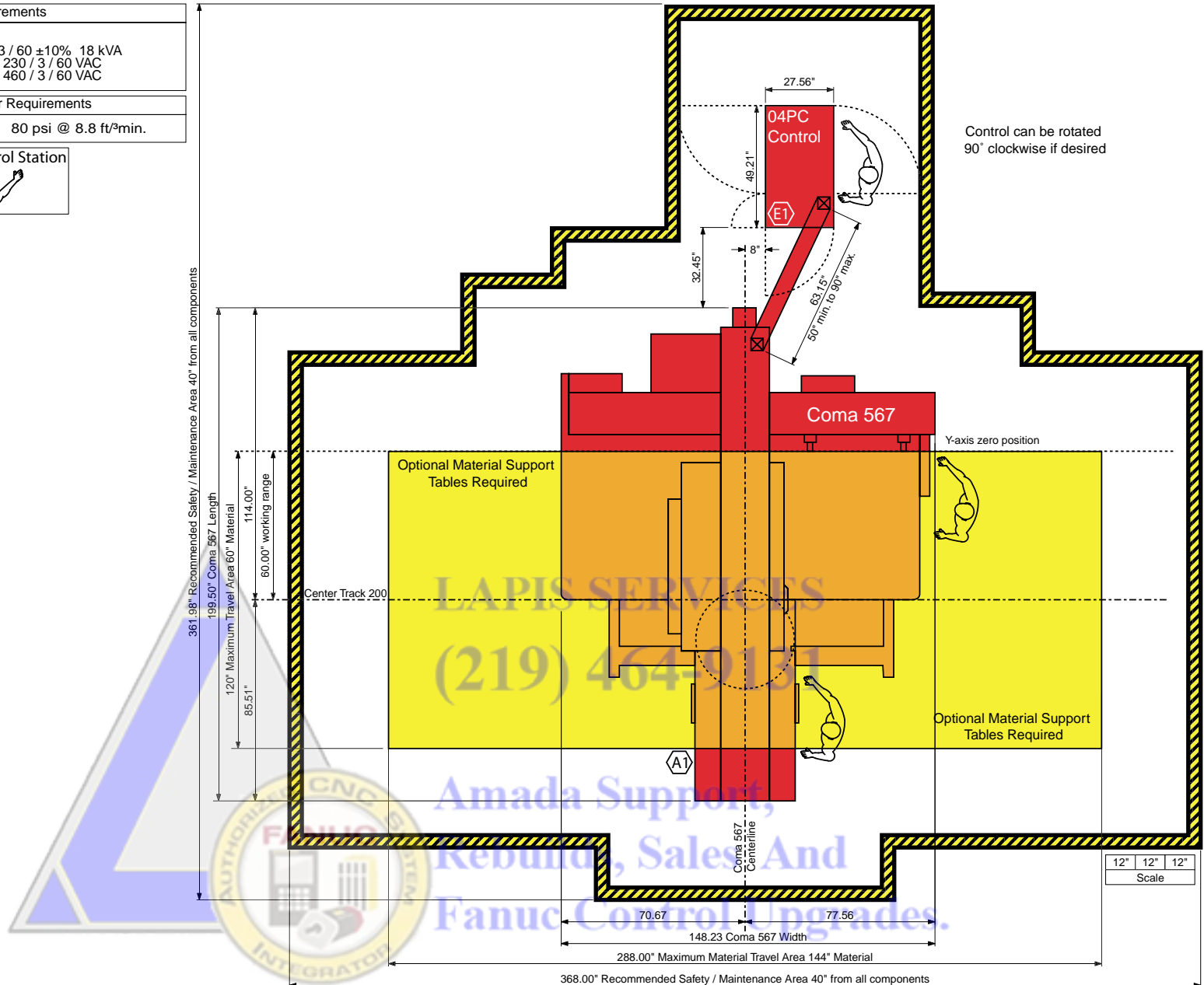

Plan View - Coma 567

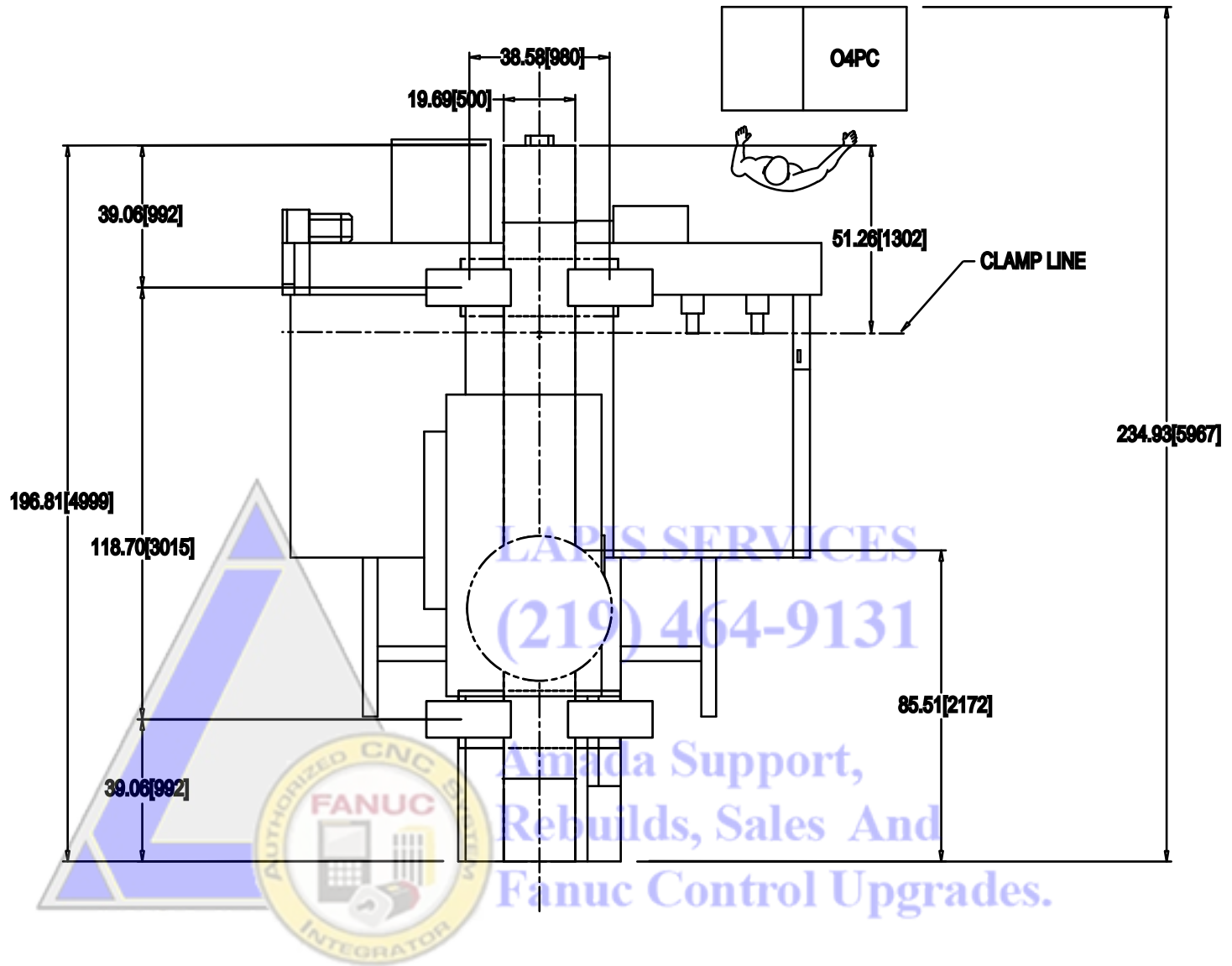

Elevation View - Coma 567

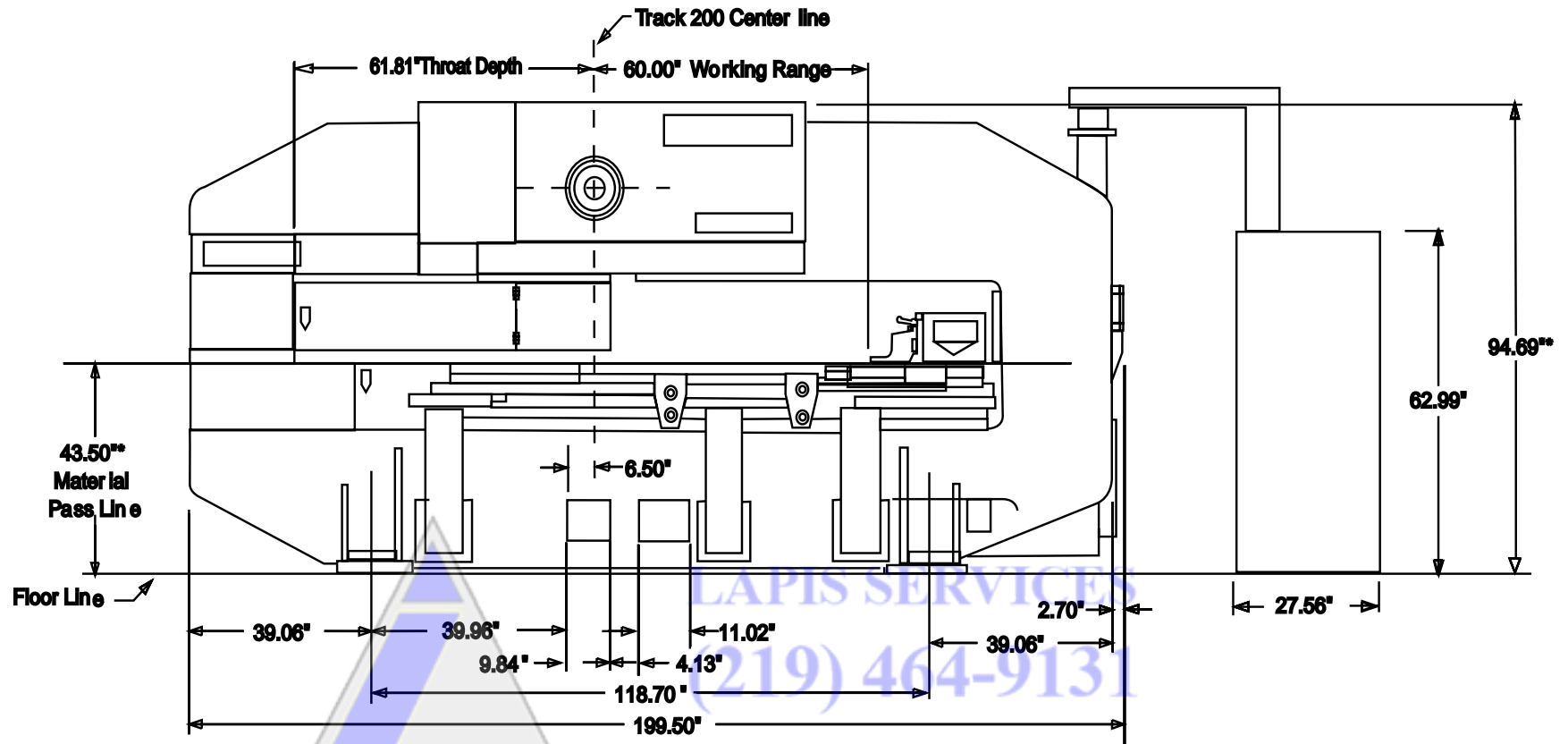

*Dimension will change with installed options



Amada Support,
Rebuilds, Sales And
Fanuc Control Upgrades.

LAPISINC.COM

End View - Coma 567

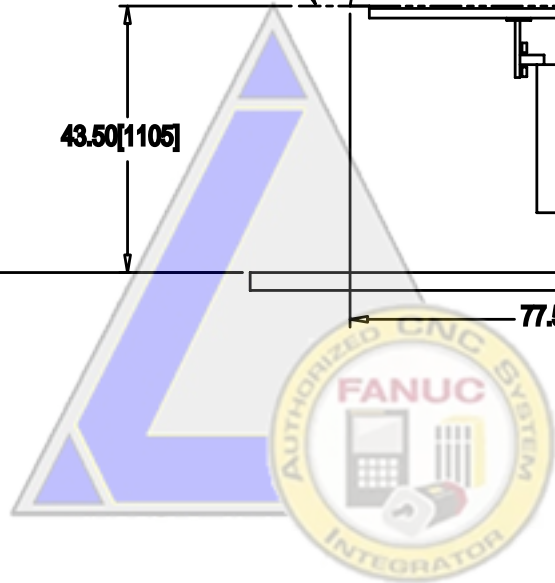
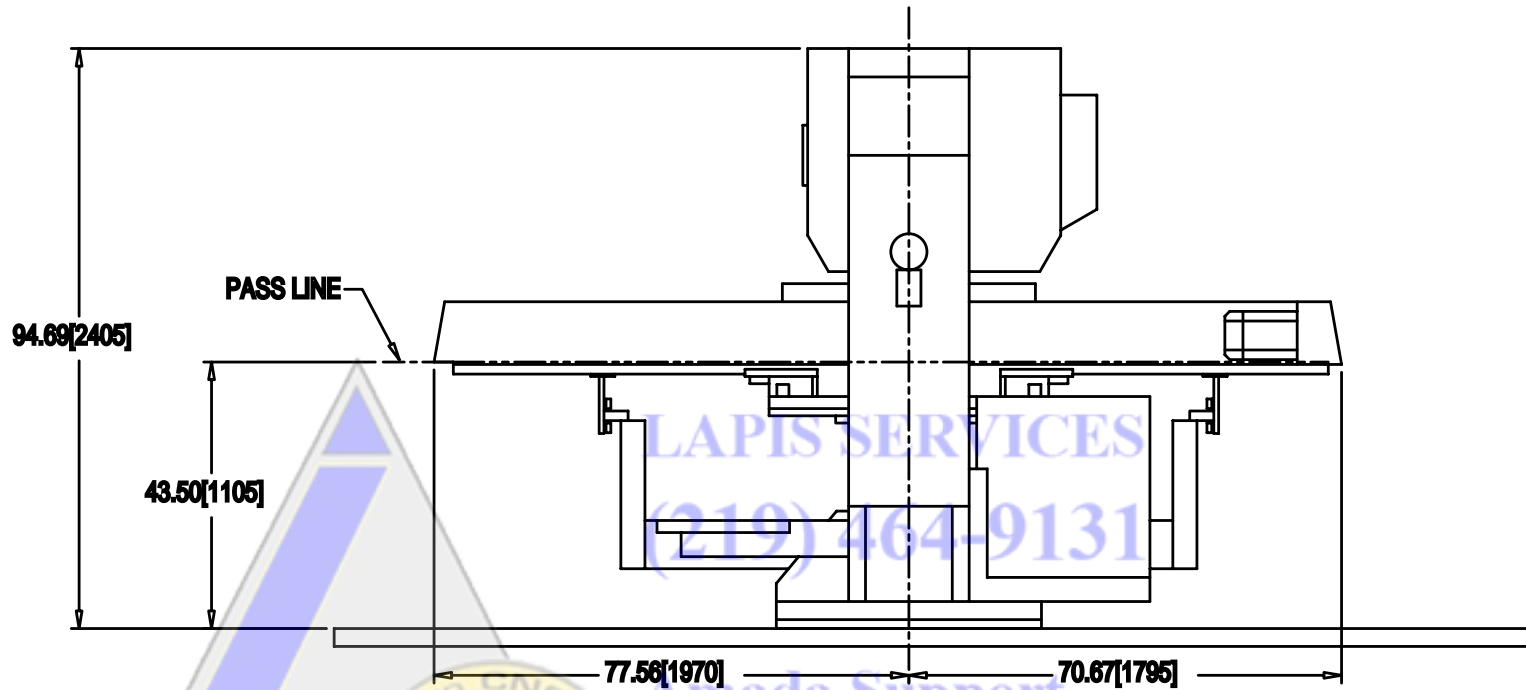

LAPIS SERVICES
(219) 464-9131
Amada Support,
Rebuilds, Sales And
Fanuc Control Upgrades.
LAPISINC.COM

Foundation Requirements

The Coma 567 does not require a special foundation to perform as expected, however there are minimum requirements that an existing floor must meet in order to assure machine reliability and tool life. If the existing floor does not meet the following minimum requirements, plans for a recommended foundation are given on page 20, *Plan View - Foundation*.

The minimum acceptable floor conditions to assure a successful installation are:

- The area of the floor where the machine frame is to be located must be a single, homogeneous slab in good condition. There must be no cracks or other signs of deterioration of the floor.
- The floor must be 4" to 6" thick.
- The floor must be capable of supporting 3.5 tons/ft².
- The floor must be level to 0.032"/ft.

If the existing floor meets the minimum requirement list above, it must still be inspected carefully when the anchor-bolt holes are cut. Voids under the floor, or wetness (not associated with the hole cutting procedure) should be considered signs of an inadequate floor and a new machine location or new foundation must be considered.

It is the customer's responsibility to determine that the floor meets these minimum requirements. Placing the machine on an inadequate, cracked floor, or straddling seams in a floor may be grounds for voiding the machine warranty!

Amada America Inc. does not recommend the use of vibration isolating mounts under the machine feet, as these devices have been shown to increase the vibration within the machine frame, increasing the likelihood of vibration related problems. Solid leveling devices are acceptable provided they incorporate a means of anchoring the machine to the floor with the supplied J-bolts or alternative anchoring method.



LAPIS SERVICES
(219) 464-9131

Amada Support,
Rebuilds, Sales And
Fanuc Control Upgrades.

LAPISINC.COM

Foundation Anchoring Procedure

An ideal foundation is given on the following pages. This foundation must be used if the existing floor cannot meet the minimum requirements to support the machine.

The foundation must consist of a single, homogeneous slab. The foundation must be level to within 0.032" / ft. Anchoring the Coma 567 to the floor using the anchor-bolts supplied is essential to ensure reliable performance. Amada generally recommends that the foundation have a minimum load bearing capacity of 3.5 ton/ft². It is the purchaser's responsibility to determine that the foundation meets these requirements.

Please note the following:

- The base plates, shims, anchor bolts, nuts, and washers are shipped with the Coma 567.
- The concrete J-bolt pads should be filled after the machine is placed on the foundation.

Foundation J-bolt Detail

See page 23, *Foundation / Floor J-bolt Mounting Procedure*, for proper method of mounting the Coma 567 on the foundation.

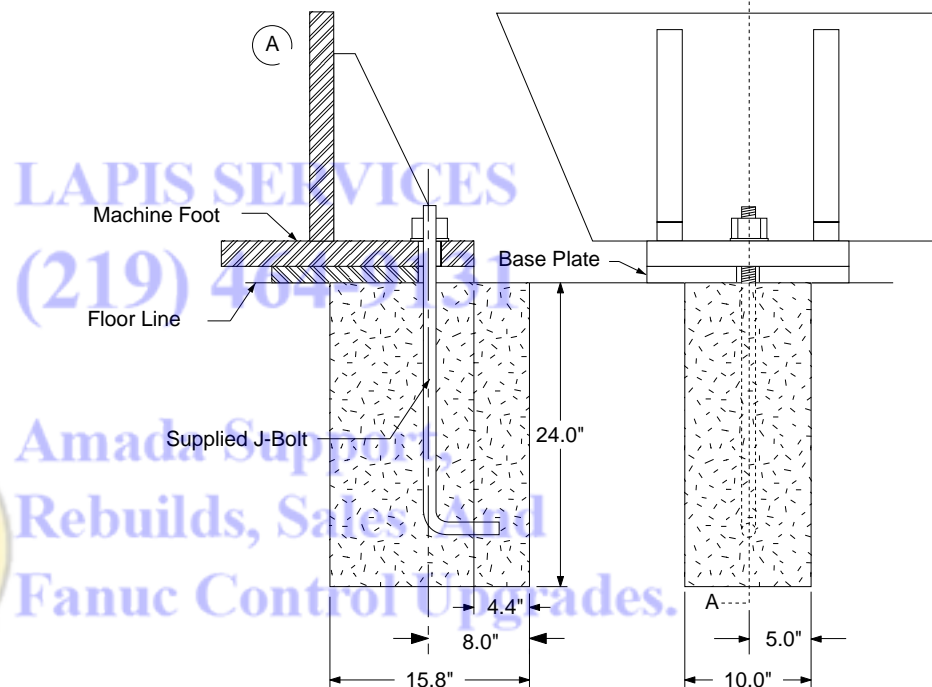
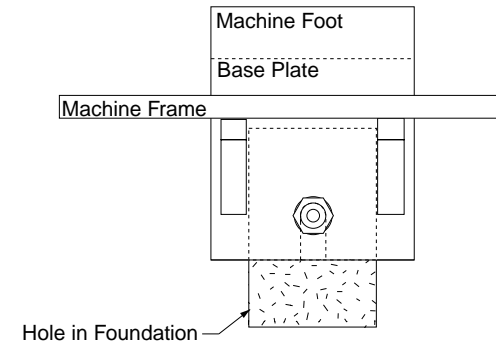

LAPIS SERVICES
 (219) 464-9341
 Amada Support
 Rebuilds, Sales And
 Fanuc Control Upgrades.
 LAPISINC.COM

Plan View - Foundation Coma 567

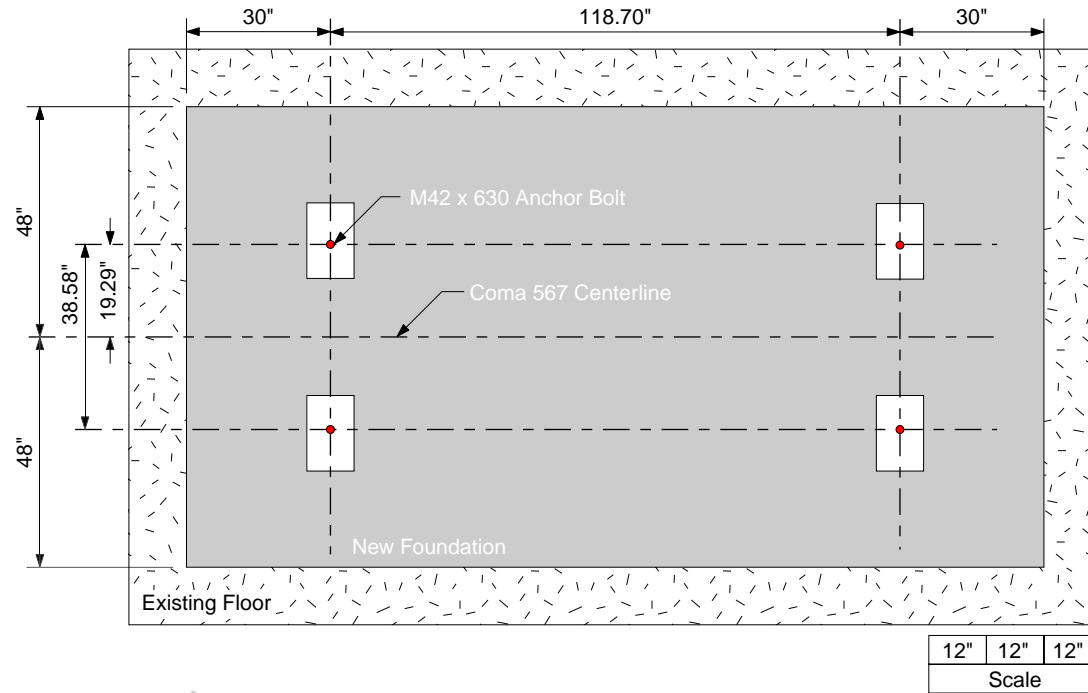

Elevation - Foundation Coma 567

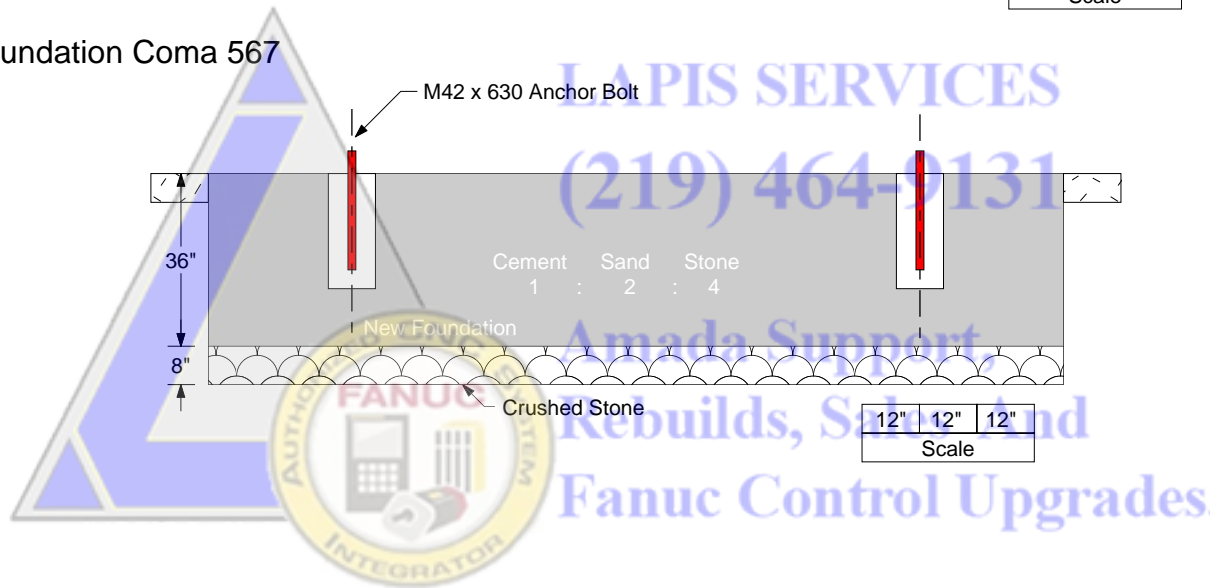

Machine Anchoring Requirements Coma 567

To maintain machine reliability, extend tool life, and remain level over an extended period the Coma 567 must be anchored in place on an adequate floor or foundation.

At a minimum the floor must consist of a single, homogeneous slab, level to within 0.032"/ft², and capable of supporting 3.5 tons/ft². It is the purchaser's responsibility to determine that the floor meets these minimum requirements.

Floor J-bolt Mounting Hole Detail (saw cut hole)

This machine mounting method should be used only if the floor is of such quality that it will support the weight of the machine with the anchor J-bolts used only for maintaining the location of the machine.

Plan - Floor J-bolt Mounting Hole (saw cut hole)

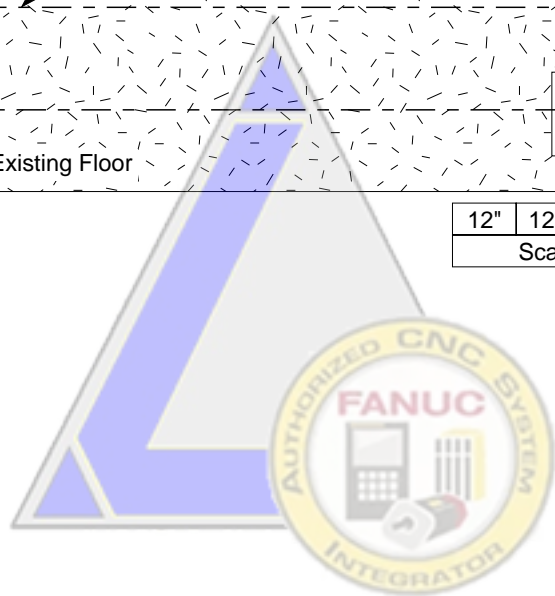
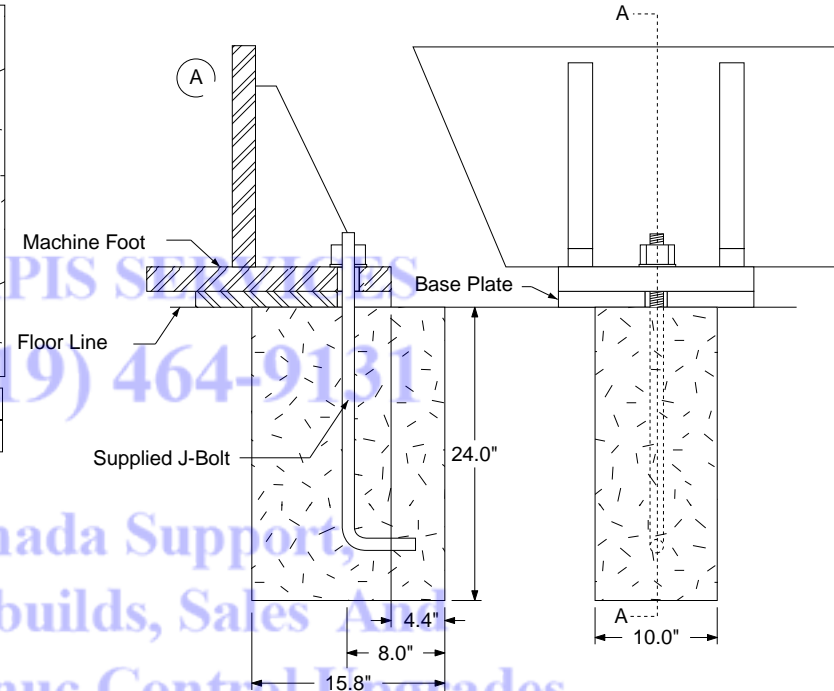
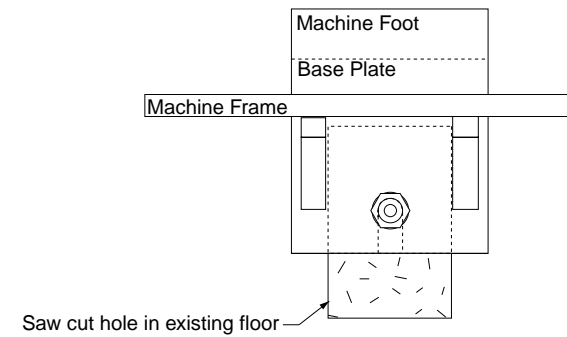
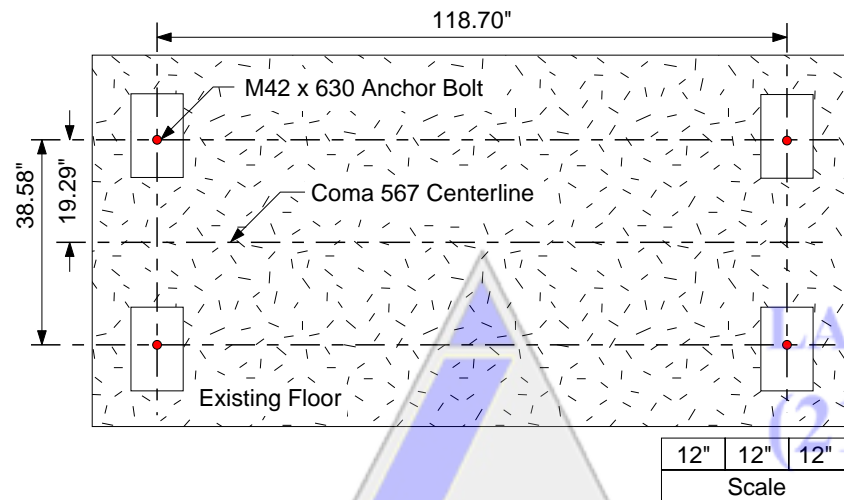

Amada Support,
Rebuilds, Sales And
Fanuc Control Upgrades.
LAPISINC.COM

Alternative Floor J-bolt Mounting Hole Detail (Core Drill)

This machine mounting method should only be used if the floor is of such quality that it will support the weight of the machine with the anchor J-bolts used only for maintaining the location of the machine.

Plan - J-bolt Mounting Hole (Core Drill)

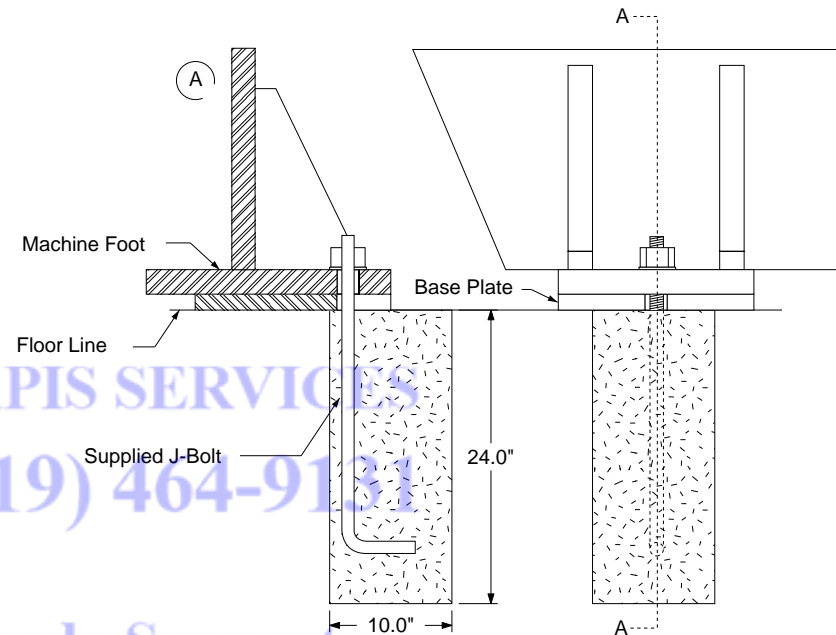
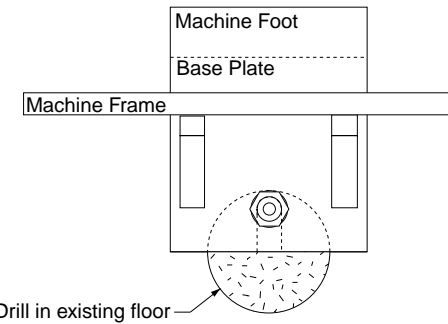
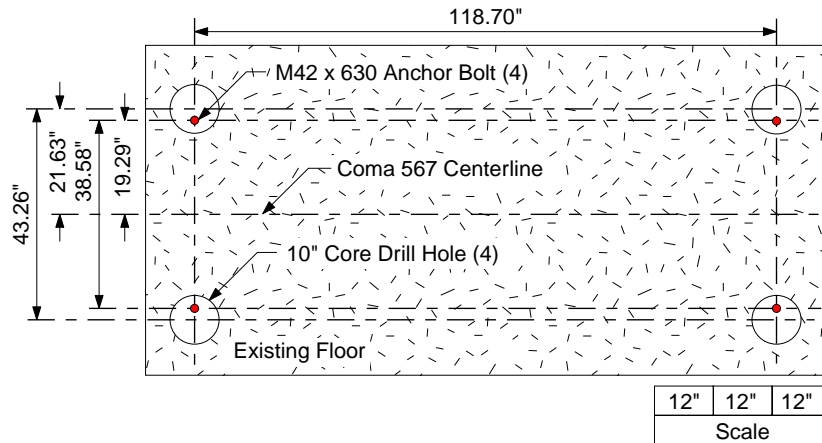

LAPIS SERVICES
 (219) 464-9131
 Amada Support,
 Rebuilds, Sales And
 Fanuc Control Upgrades.

LAPISINC.COM

Foundation / Floor J-bolt Mounting Procedure

Step 1. Saw cut or Core drill a hole in the existing floor and remove the underlying dirt to the required 24" depth.

See Floor J-bolt Mounting Hole Plan View (saw cut hole) or Alternative J-bolt Mounting Method Plan View (Core Drill) for correct layout dimensions of the four anchor holes required.

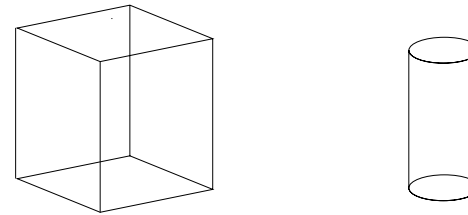

Step 2. Set base plate over the hole.

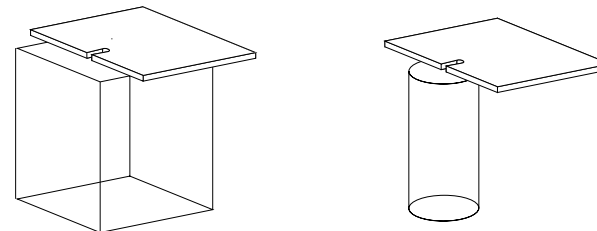

Step 3. Set the machine on the base plate.



LAPIS SERVICES
(219) 464-9131
Amada Support,
Rebuilds, Sales And
Fanuc Control Upgrades.

LAPISINC.COM

Step 4. Set the J-bolt through the hole in machine foot, attach washer and nut to hold J-bolt in place.

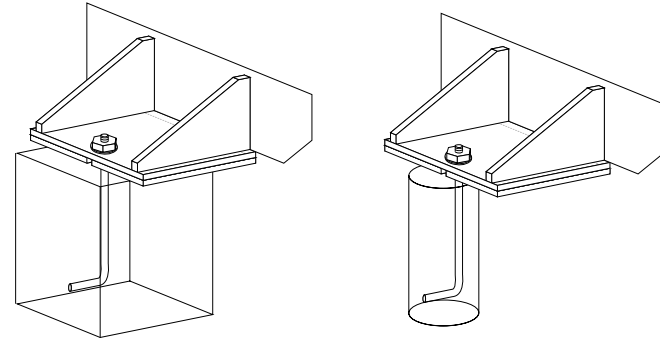

Step 5. Pour the Concrete. Ensure that the J-bolt remains correctly aligned to the machine frame during the pouring and hardening time of the concrete. Ensure that the concrete level is equal to the floor level

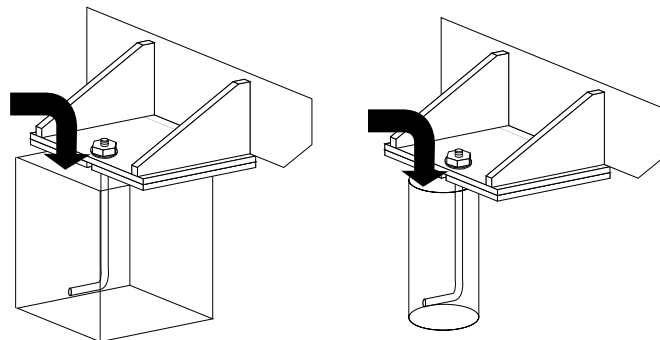

Step 6. To complete the mounting procedure, level the machine frame by inserting leveling shims between the machine foot and base plate.

See *Leveling the Machine* section for correct procedure.

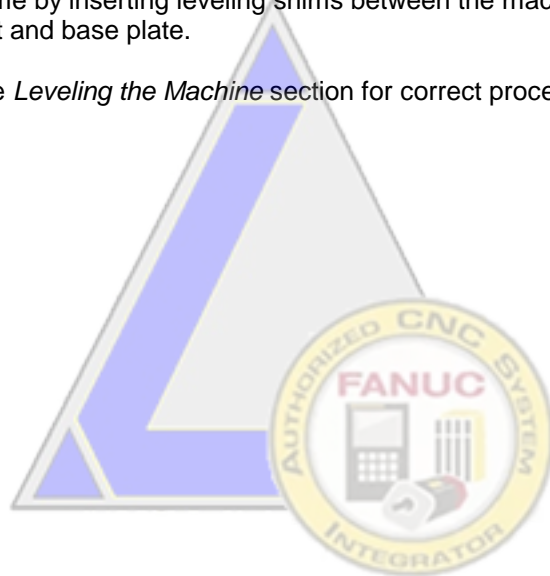
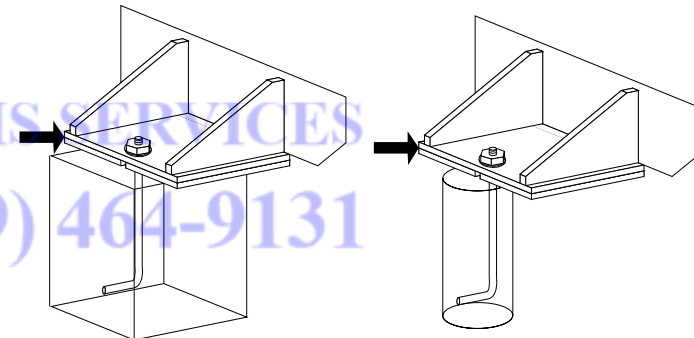

LAPIS SERVICES
(219) 464-9131

Amada Support,
Rebuilds, Sales And
Fanuc Control Upgrades.

LAPISINC.COM

Alternative Anchoring Method (Drilled Hole with Anchor Rod and Adhesive)

This machine mounting method should only be used if the floor is of such quality that it will support the weight of the machine with the Anchor Rod used only for maintaining the location of the machine.

Plan - J-bolt Mounting Hole (Drilled Hole with Anchor Rod and Adhesive)

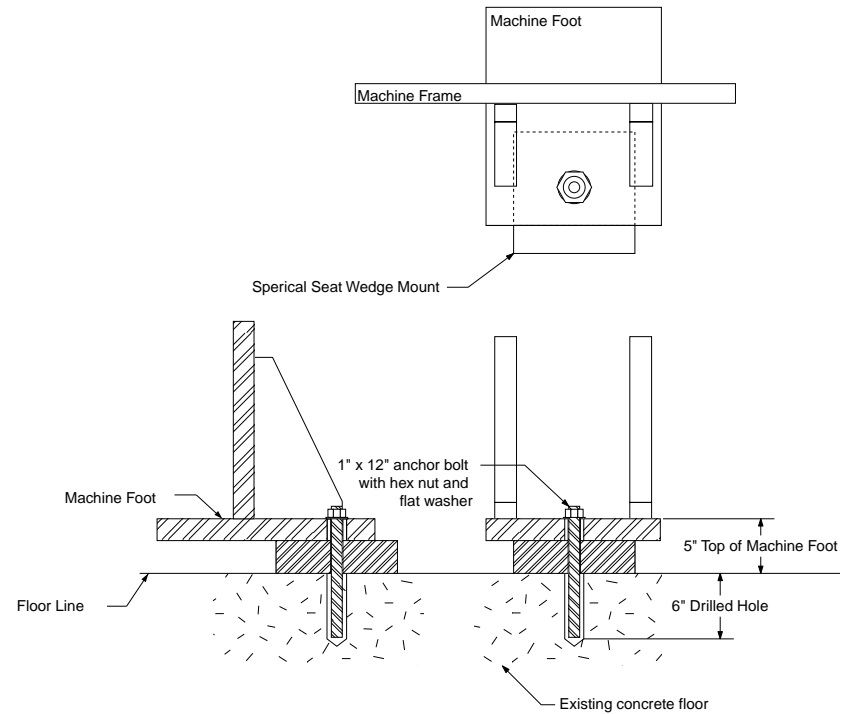
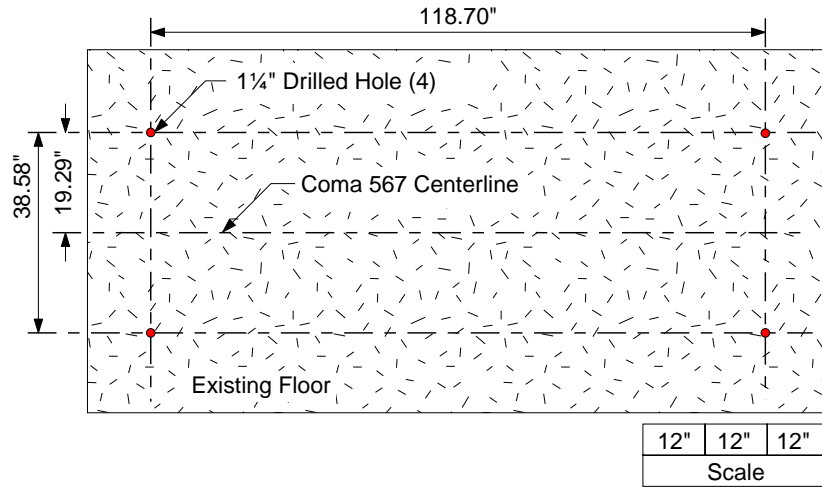

LAPIS SERVICES
(219) 464-9131

Amada Support,
Rebuilds, Sales And
Fanuc Control Upgrades.

LAPISINC.COM

Drilled Hole with Anchor Rod and Adhesive Mounting Procedure

- Step 1. Drill the four Anchor Rod holes in the existing floor.
The holes should be drilled approximately 6" deep.
See Alternative Floor Bolt Mounting Method Plan View (Drilled Hole with Adhesive Anchor Rod) for correct layout dimensions.

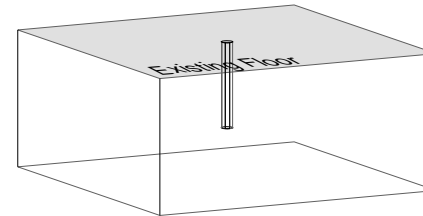

- Step 2. Set the Amada Machine Leveling Plates over the drilled holes

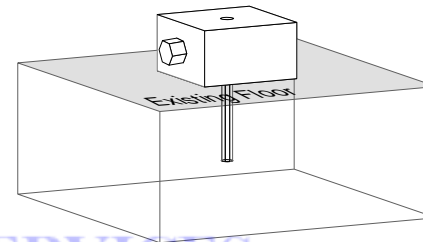

- Step 3. Set the machine on the machine leveling plates.
Step 4. Level the machine frame by adjusting the Amada machine leveling plates.
See *Leveling the Machine* section for correct procedure.

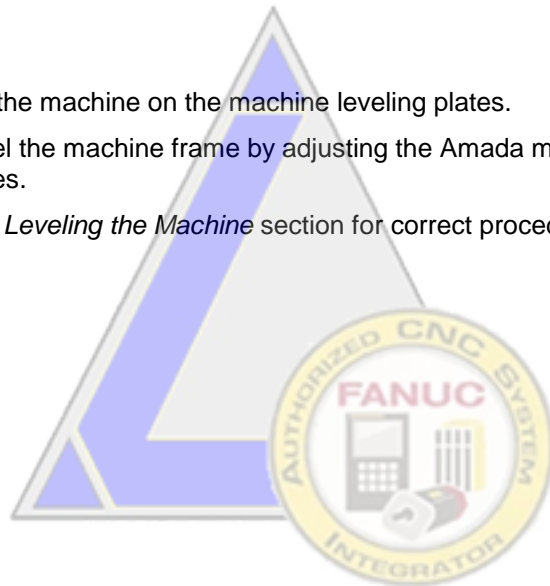
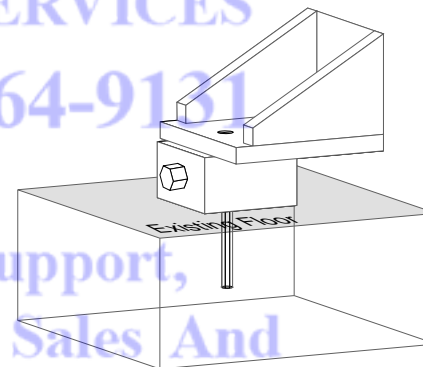

LAPIS SERVICES
(219) 464-9131
Amada Support,
Rebuilds, Sales And
Fanuc Control Upgrades.

LAPISINC.COM

Step 5 Fill each of the Anchor Rod holes to within 2 inches of the floor surface with the Adhesive compound. Do not overfill.

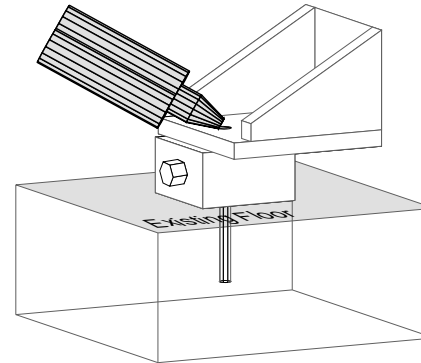

Step 6 Attach the hex nut and flat washer on the Anchor Rod and place the Anchor Rod into the drilled hole.

Using a twisting motion to move the Anchor Rod through the epoxy compound, seat the flat washer and hex nut against the top of the machine foot.

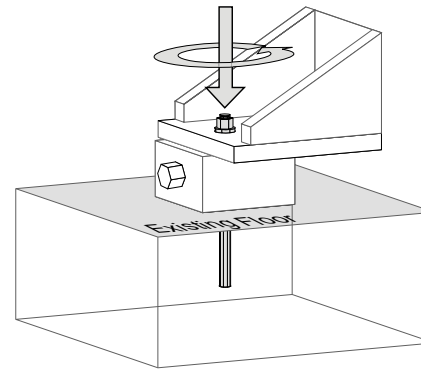

Step 7 Allow the Adhesive to harden for 24 hours.

Step 8. Tighten the 4 hex nuts.

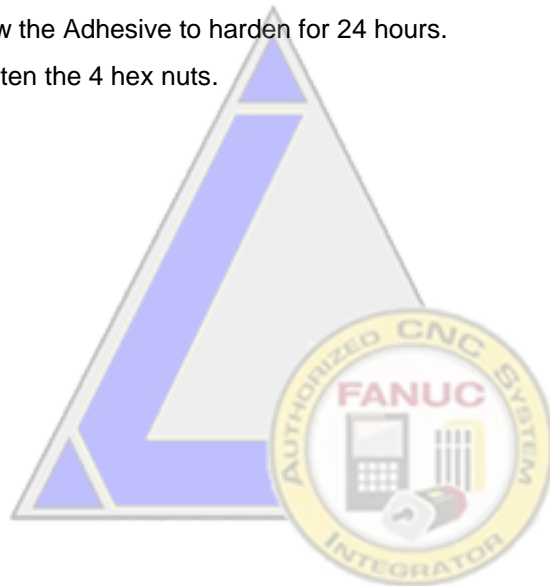
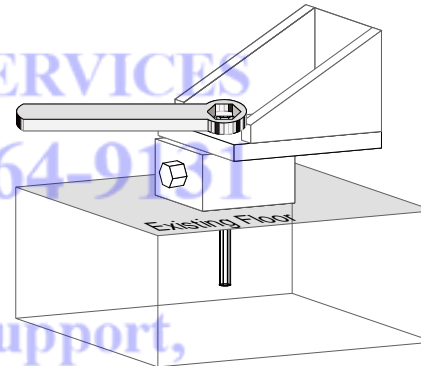

LAPIS SERVICES
(219) 464-9151
Amada Support,
Rebuilds, Sales And
Fanuc Control Upgrades.

LAPISINC.COM

Removing the Protective Coating

The Coma 567 must be thoroughly cleaned of protective coating. The sheet metal guards can be removed from around the turret to allow cleaning of the upper and lower turrets, tool bores and die holders.

Please note the following:

- Remove wrapping paper from the X and Y-axes ball screws, then remove the protective coating.
- Remove the wrapping paper from the X and Y LM guides then remove the protective coating, make sure that you remove the paper from both sides of the carriage.
- Clean die holders one at a time. Remove a die holder, clean and replace it before removing the next die holder. If the die holders are mixed up, serious turret alignment problems may occur.
- A suitable solvent should be used to remove the protective coating.

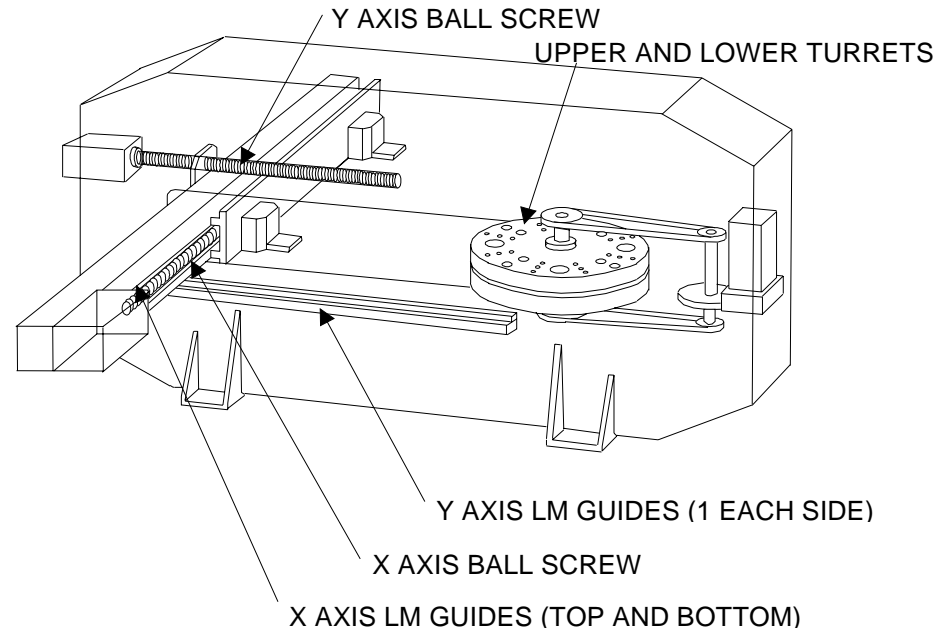

LAPIS SERVICES
(219) 464-9131

**Amada Support,
Rebuilds, Sales And
Fanuc Control Upgrades.**

LAPISINC.COM

Machine Leveling

Proper Machine leveling is critical to the Coma 567 performing as designed.

Materials and tools required:

Supplied with the machine:

Assorted thickness machine leveling shim stock

Anchor bolts

Supplied by AESI service:

Spirit level capable of reading 0.0005"/ft

One (1) 12 ton hydraulic bottle jack

Not supplied:

Additional shim stock of 0.005" thickness may be required to achieve a properly leveled machine.

Rocking Test

After the machine frame has been leveled the use of the following G-code is necessary to determine that the machine frame is properly leveled and balanced.

Should the machine frame vibrate or move excessively during the rocking test the machine frame must be re-leveled using the procedure in this manual.

Should the proper leveling technique not eliminate the excessive frame motion, consideration must be given to relocation of the machine or replacement of the existing floor with an adequate foundation.

Repeat test with X-axis movement values of 0.500", 1.000", and 4.000"

G92X72.000Y60.000

N1

G91G70X-.25Tttt(Use any valid tool number)

G70X.25

M97P1

G50

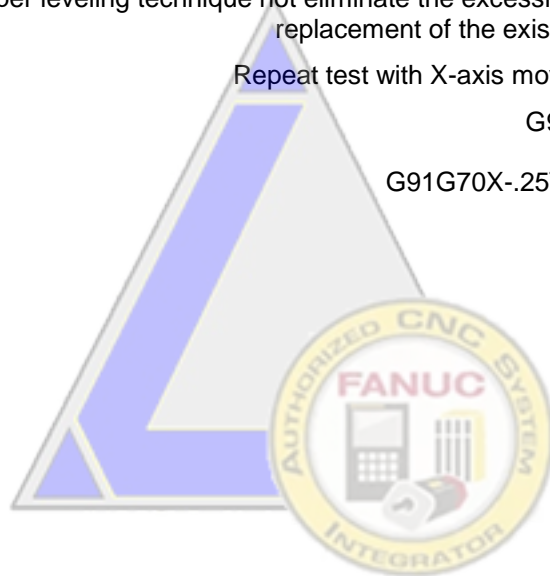

Amada Support,
Rebuilds, Sales And
Fanuc Control Upgrades.

LAPISINC.COM

Floor Condition: Crowned

The flatness of the floor plays an important step in the leveling procedure of the machine. To properly level the machine the weight bearing points must be as far from the centerline of the machine frame as possible.

Should a condition known as crowning exist the weight bearing points of the machine may not be far enough from the machine centerline to ensure a stable machine.

Under these conditions, a procedure known as *Half-Shimming* should be used.

To move the weight bearing points further from the machine centerline the use of half-shims of .125" thick on top of the base plate as shown is recommended.

After the half-shims are installed and the machine frame is leveled, use the rocking test to determine that the machine frame is stable enough to allow production without damaging the machine.

Under extreme conditions the use of half-shims may not move the machine weight bearing points far enough from the machine centerline to ensure the machine frame is stable.

Under these conditions, a more suitable location must be found for the machine, or a new foundation for the machine will be necessary.

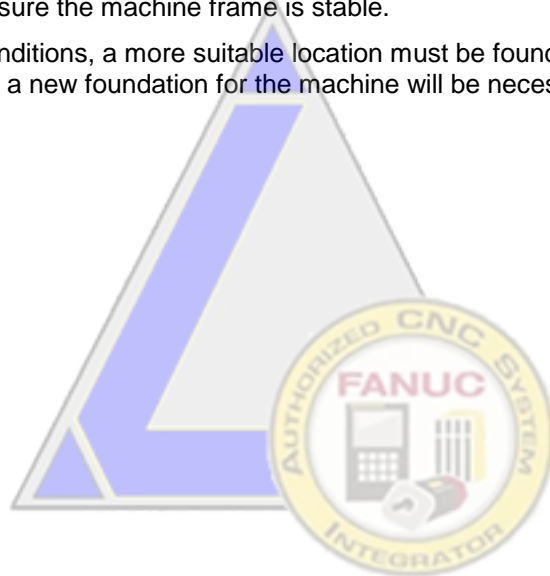
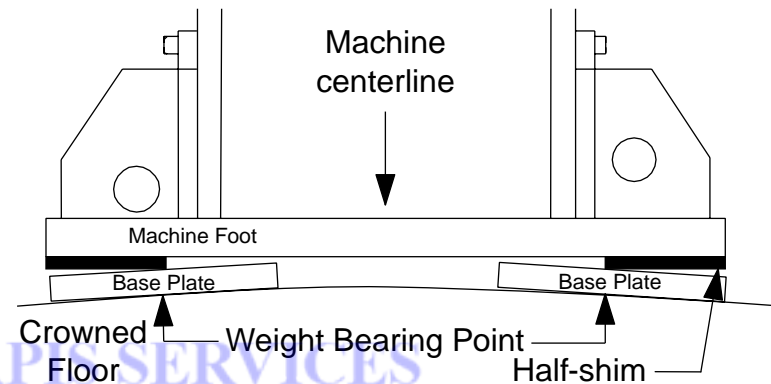
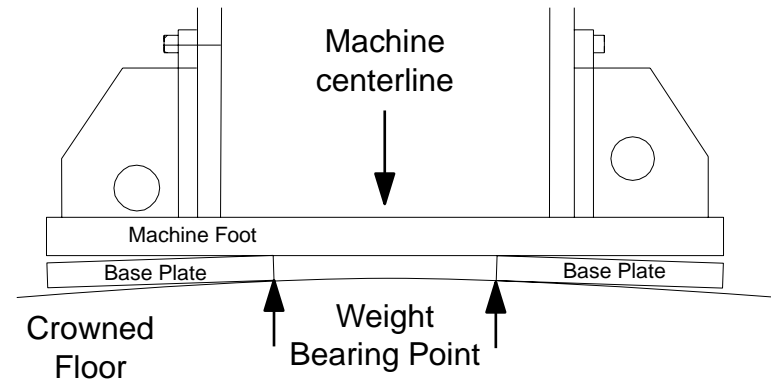

(219) 464-9131

Amada Support,
Rebuilds, Sales And
Fanuc Control Upgrades.

LAPISINC.COM

Floor Condition: Sloped

The slope of the floor plays an important step in the leveling procedure of the machine. To properly level the machine the weight bearing points must be as far from the centerline of the machine frame as possible.

Should the floor slope excessively the weight bearing points of the machine may not be far enough from the machine centerline to ensure a stable machine.

Under these conditions, a procedure known as *Half-Shimming* should be used.

To move the weight bearing points further from the machine centerline the use of half-shims of .125" thick on top of the base plate and leveling shims as shown is recommended.

After the half-shims are installed and the machine frame is leveled, use the rocking test to determine that the machine frame is stable enough to allow production without damaging the machine.

Under extreme conditions the use of half-shims may not move the machine weight bearing points far enough from the machine centerline to ensure the machine frame is stable.

Under these conditions a more suitable location must be found for the machine, or a new foundation for the machine will be necessary.

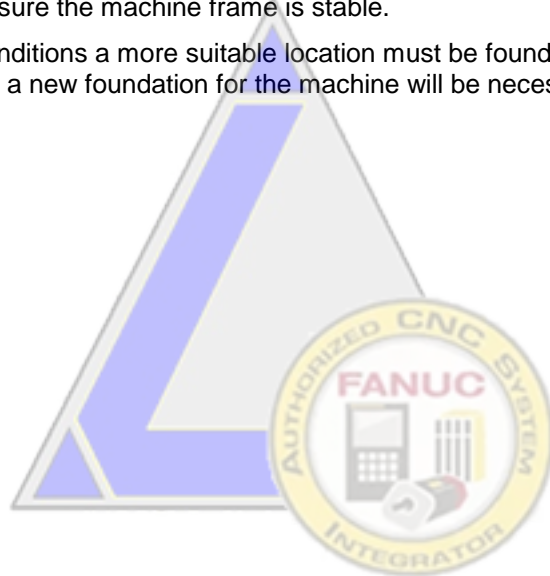
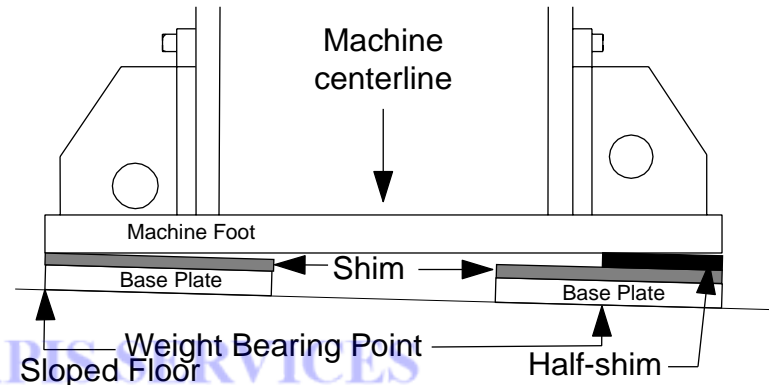
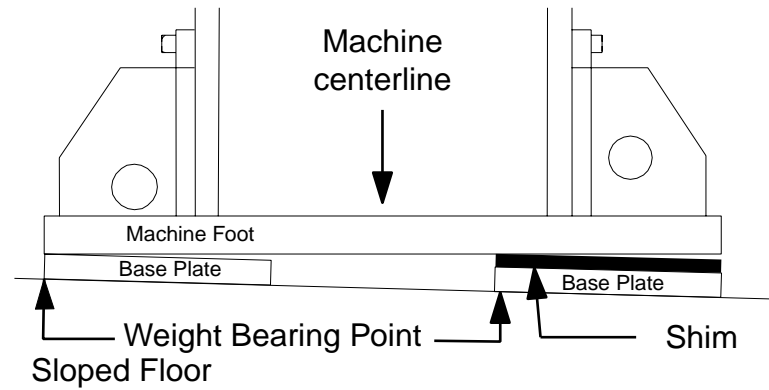

LAPIS SERVICES
 (219) 464-9131
 Amada Support,
 Rebuilds, Sales And
 Fanuc Control Upgrades.
 LAPISINC.COM

Leveling Procedure

1. Determine the high end of machine frame by placing the spirit level on the turret to measure the level of the machine frame in the y-axis.
2. Use the bottle jack to lift the low end of the machine frame.
3. With the turret end of the machine frame slightly higher than the carriage end. Shim beneath both machine feet and the base plates until the machine frame measures near level on the y-axis.
4. Center the bottle jack under the carriage end of the machine frame.
5. Lift the machine frame until all weight is off the machine feet at the carriage end of the machine frame. Lift the machine frame as little as possible to take the weight off the base plates.

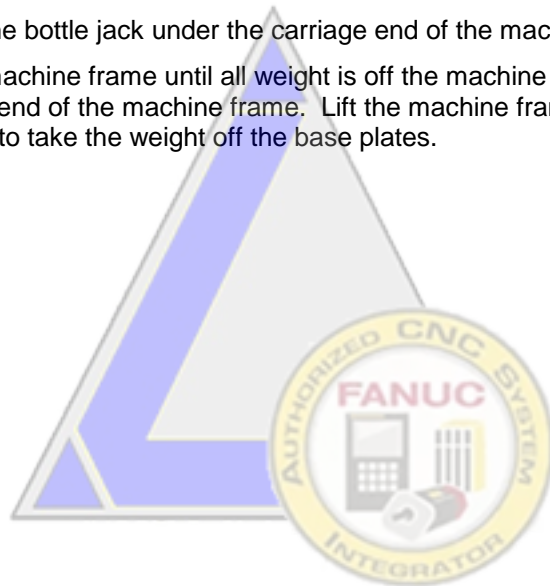
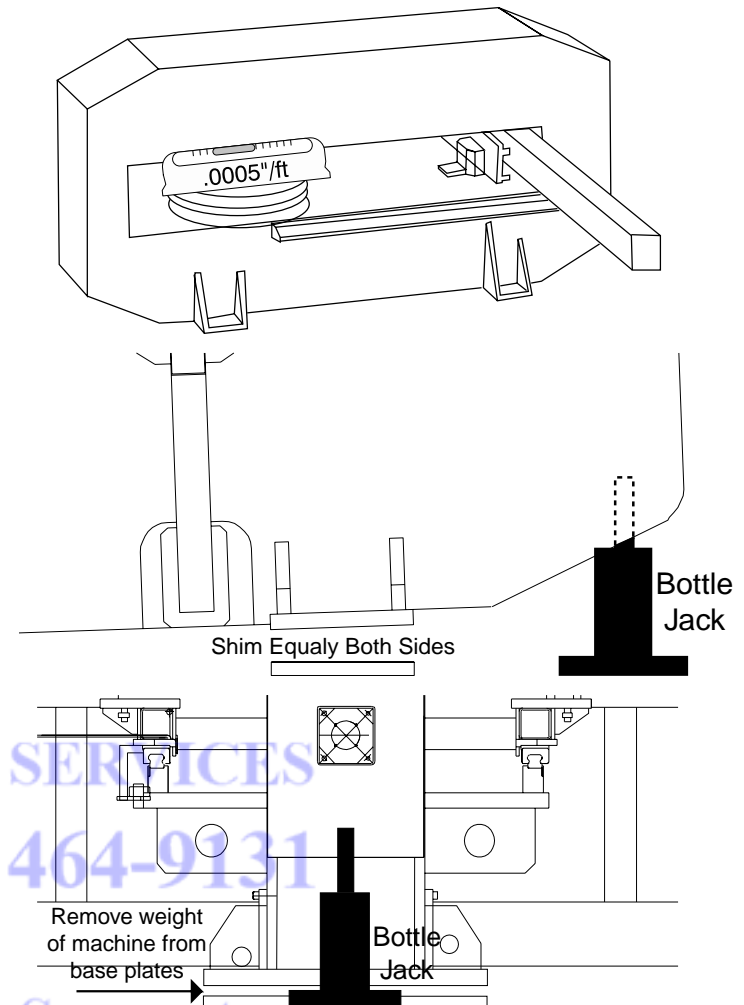

LARIS SERVICES
 (219) 464-9131
 Amada Support,
 Rebuilds, Sales And
 Fanuc Control Upgrades.

LARISINC.COM

6. With the machine supported on the bottle jack at the carriage end of the machine frame and the machine feet at the turret end of the machine frame, place the spirit level on the turret.
7. Measure and record the level of the turret in the x-axis direction.
8. Lower the machine frame to place all machine feet in contact with the leveling shims and base plates.

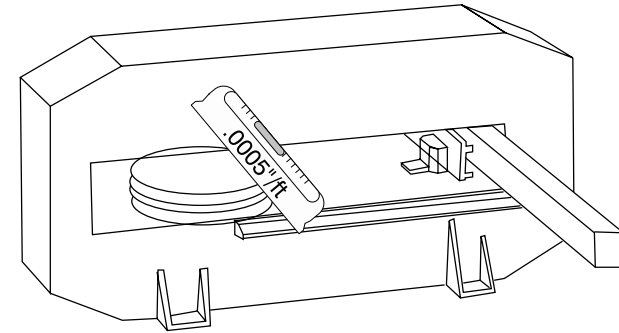

9. Lift the turret end of the machine frame to allow shimming between the machine feet and base plates to level the machine frame in the x-axis direction.
10. Repeat steps 5 to 9 until the machine frame measures level to 0.0005"/ft in step 7, then continue.

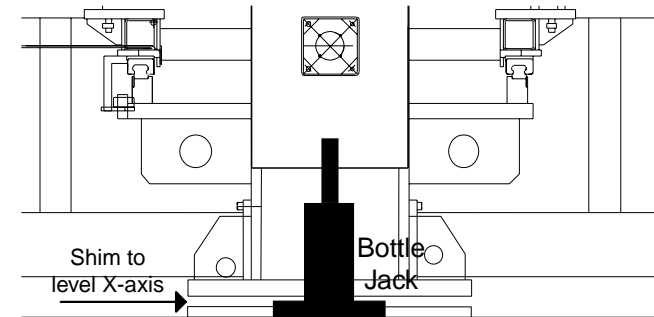

11. With the weight of the carriage end of the machine supported by the bottle jack. Monitor the level of the turret in the x-axis, as the bottle jack is slowly lowered to place the carriage end machine feet in contact with the base plates.
12. Any change in the level indicates that the carriage end of the machine needs to be leveled.

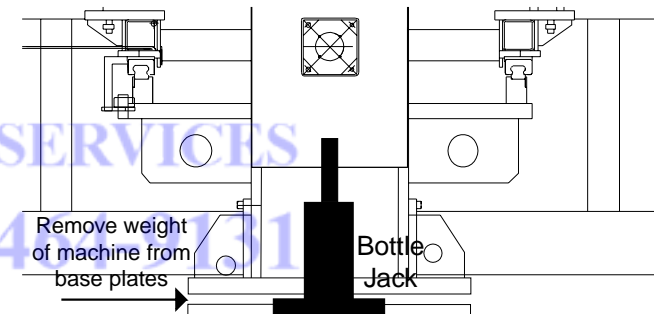

13. Lift the carriage end of the machine frame to allow shimming between the machine feet and base plates to level the carriage end of the machine frame in the x-axis direction.
14. Repeat steps 11 and 13 until no difference in level is noted when the machine weight is on or off the base plates and shims, then continue.

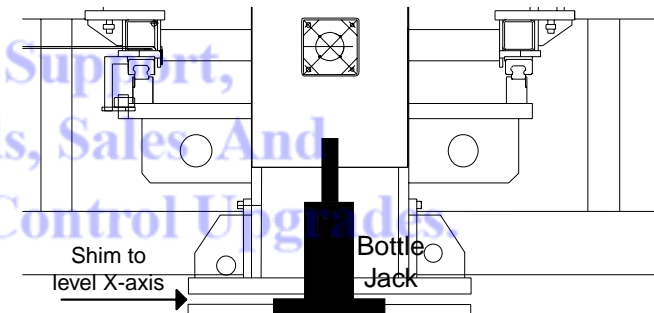

15. With all of the machine feet setting on the shims and base plates place the spirit level on the turret to measure and note the level of the machine frame in the y-axis.
16. Using the bottle jack lift the low end of the machine frame and shim equally under both machine feet to level the machine frame in the y-axis.
17. Repeat steps 15 to 16 until the machine frame measures level to 0.0005"/ft in the y-axis then continue.
18. Run the machine using the rocking test G-code to determine that the machine frame is leveled adequately. Should excessive movement of the machine frame be noticed check for the conditions discussed in *Floor Condition Crowned* and *Floor Condition Sloped*
19. Tighten the anchor bolt nuts to prevent the machine frame from moving when in use. Monitor the machine level while tightening the anchor bolts to assure the machine level is not changed.

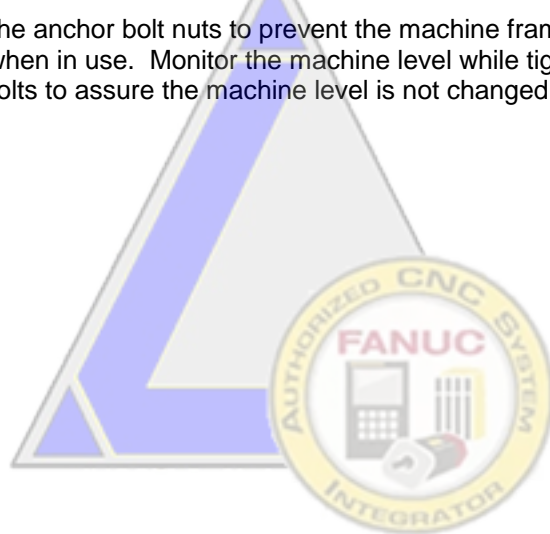
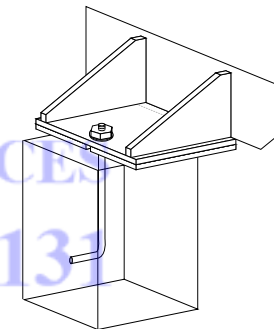
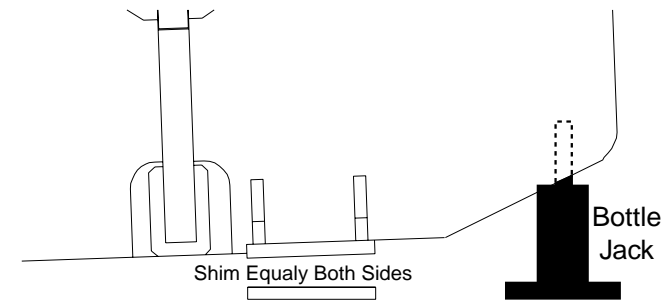
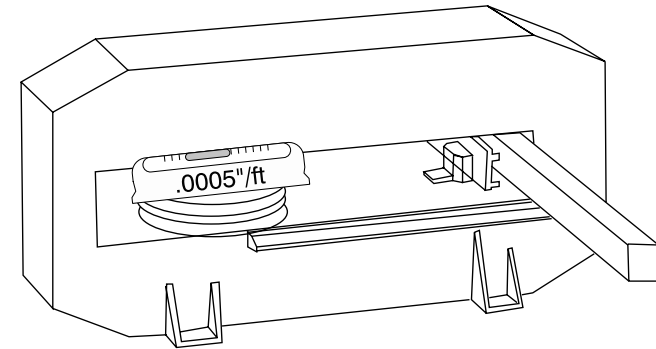

LAPIS SERVICES
(219) 464-9131

Amada Support,
Rebuilds, Sales And
Fanuc Control Upgrades.

LAPISINC.COM