

# Vipros 357 Queen with Fanuc 18PC User Pre-installation Guide



Amada Support,  
Rebuilds, Sales And  
Fanuc Control Upgrades.

LAPISINC.COM

Amada America Inc.  
7025 Firestone Blvd.  
Buena Park CA. 90621  
Phone: (714) 739 2111  
Fax.: (714) 739 4099  
Email [info@amada.com](mailto:info@amada.com)

## ***Warning***

- ❑ Qualified personnel must complete all work.
- ❑ Do not apply power to the Vipros 357 Queen until an A.E.S.I. (Amada Engineering and Service Incorporated) Engineer is present and has instructed you to do so.
- ❑ Considerable effort has been made to ensure that this manual is free of inaccuracies and omissions. However, as we are constantly improving our product, some of the data contained herein may not exactly reflect the latest revisions to the Vipros 357 Queen. If in doubt concerning a specific item, please contact your local Amada America sales person for clarification, or check our Internet site, <http://www.amada.com> for the latest release of this document.



**LAPIS SERVICES**  
**(219) 464-9131**

**Amada Support,  
Rebuilds, Sales And  
Fanuc Control Upgrades.**

**LAPISINC.COM**

# Contents

Introduction .....	5
Specifications - Motion Package .....	6
Specifications - Punching System .....	7
Turret Configuration - 58 Station - 2 Auto-Index .....	8
Specifications - Fanuc 18PC Controller .....	9
Specifications - Hydraulic Systems .....	9
Power Hydraulic Numerical Control .....	9
Hydraulic Power Unit .....	9
Supply Requirements - Electrical .....	10
Optional Equipment .....	10
Installing the Electrical Power Supply .....	11
Supply Requirements - Pneumatic.....	12
Optional Equipment .....	12
Installing the Pneumatic Supply.....	12
Planning the Location of the Vipros 357 Queen.....	13
Moving the Vipros 357 Queen .....	13
Plan View - Vipros 357 Queen.....	14
Plan View - Vipros 357 Queen with V357hs conveyor.....	15
Plan View - Vipros 357 Queen with V357hs conveyor and MP1225 loader .....	16
End View - Vipros 357 Queen.....	17
Elevation View - Vipros 357 Queen .....	18
SBC EX 5.5 Chiller.....	19
SBC EX 5.5Chiller Placement.....	19
Chiller Connections.....	20
Foundation Requirements.....	21
Foundation Anchoring Procedure .....	22
Foundation J-bolt Detail.....	22
Plan View - Foundation Vipros 357 Queen.....	23
Elevation - Foundation Vipros 357 Queen.....	23

LAPIS SERVICES  
(219) 464-9131

Amada Support,  
Rebuilds, Sales And  
Fanuc Control Upgrades.

LAPISINC.COM

Machine Anchoring Requirements Vipros 357 Queen .....24

    Floor J-bolt Mounting Hole Detail (saw cut hole) .....24

    Plan - Floor J-bolt Mounting Hole (saw cut hole) .....24

    Alternative Floor J-bolt Mounting Hole Detail (Core Drill).....25

    Plan - J-bolt Mounting Hole (Core Drill) .....25

    Foundation / Floor J-bolt Mounting Procedure.....26

    Alternative Anchoring Method (Drilled Hole with Anchor Rod and Adhesive) .....28

    Plan - J-bolt Mounting Hole (Drilled Hole with Anchor Rod and Adhesive).....28

    Drilled Hole with Anchor Rod and Adhesive Mounting Procedure .....29

Removing the Protective Coating.....31

Machine Leveling .....32

    Rocking Test.....32

    Floor Condition: Crowned .....33

    Floor Condition: Sloped .....34

    Leveling Procedure .....35



**LAPIS SERVICES**  
**(219) 464-9131**

**Amada Support,  
 Rebuilds, Sales And  
 Fanuc Control Upgrades.**

**LAPISINC.COM**

## Introduction

This manual describes the tasks that the purchaser of a Vipros 357 Queen must complete before calling A.E.S.I. (Amada Engineering and Service Incorporated) to complete the installation and operator training.

An overview of the preparations is as follows:

- Plan the location of the Vipros 357 Queen taking into account the Recommended Safety and Maintenance areas indicated on the plan view. See page 13, *Planning the Location of the Vipros 357 Queen*.
- Prepare the Vipros 357 Queen floor or foundation as required. See page 21, *Foundation Requirements*, for details.
- Uncrate the Vipros 357 Queen and place on the foundation, but do not fill the anchor-bolt holes (if used) until after A.E.S.I. completes the initial installation.
- Install the electrical supply. See page 10, *Supply Requirements - Electrical*, for details.
- Install the pneumatic supply. See page 12, *Supply Requirements - Pneumatic*, for details.
- Remove the protective coating from the surface of the Vipros 357 Queen. See page 31, *Removing the Protective Coating*, for details.
- If additional equipment is to be installed, repeat the previous steps for each piece of additional equipment.

Note: It is the purchaser's responsibility to install any safety devices to ensure the recommended safety area.

Note: Considerable effort has been made to ensure that this manual is free of inaccuracies and omissions. However, as Amada America strives to continually improve our products, some data contained herein may not exactly reflect the latest revisions to the Vipros 357 Queen. If in doubt concerning a specific item, please contact your local Amada America sales engineer for clarification.



LAPIS SERVICES  
(219) 464-9131

Amada Support,  
Rebuilds, Sales And  
Fanuc Control Upgrades.

LAPISINC.COM

## Specifications - Motion Package

Travel Method	X and Y axes work piece movement	
Control Method	X, Y, T & C	
Drive Motors	Fanuc AC Servo (X, Y, T, C)	
Maximum Sheet Size	50" (Y) x 144" (X) with one repositioning cycle. Additional support tables are required for material lengths greater than 72"	
Maximum Sheet Thickness	Ball Transfer Table Brush Table	0.250" 0.135"
Maximum Material Weight	Ball Transfer Table Brush Table	220 lb. 110 lb.
Maximum Axis Travel	72.0" (X) by 50" (Y)	
Max. Table Speed ( X / Y / Combined )	2559 ipm / 1968 ipm / 3228 ipm	
Punching Accuracy	±0.004"	
Positioning Accuracy	±0.001"	
Repeatability	±0.001"	



**LAPIS SERVICES**  
**(219) 464-9131**

**Amada Support,  
Rebuilds, Sales And  
Fanuc Control Upgrades.**

**LAPISINC.COM**

## Specifications - Punching System

Press Capacity	33 Tons		
Press Stroke	1.575"		
Stroke Rate (X/Y)	Pitch	Stroke	Stroke Rate
	0.079"	0.118"	520/420
	0.079"	0.236"	360/360
	0.315"	0.315"	275/275
	1.000"	0.315"	275/240
Maximum Hole Diameter	4.500"		
Tool Type	Amada Thick Turret		
Turret Rotation Speed	30 RPM		
Feed Clearance	0.787"		



**LAPIS SERVICES**  
**(219) 464-9131**

**Amada Support,  
Rebuilds, Sales And  
Fanuc Control Upgrades.**

**LAPISINC.COM**

# Turret Configuration - 58 Station - 2 Auto-Index

PEGA 345, PEGA 345 King, PEGA 357, PEGA 367  
 COMA 555, COMA 557, COMA 567, COMA 588  
 VIPROS 345, VIPROS 357, VIPROS 367  
 VIPROS 357 Queen, VIPROS 367 Queen

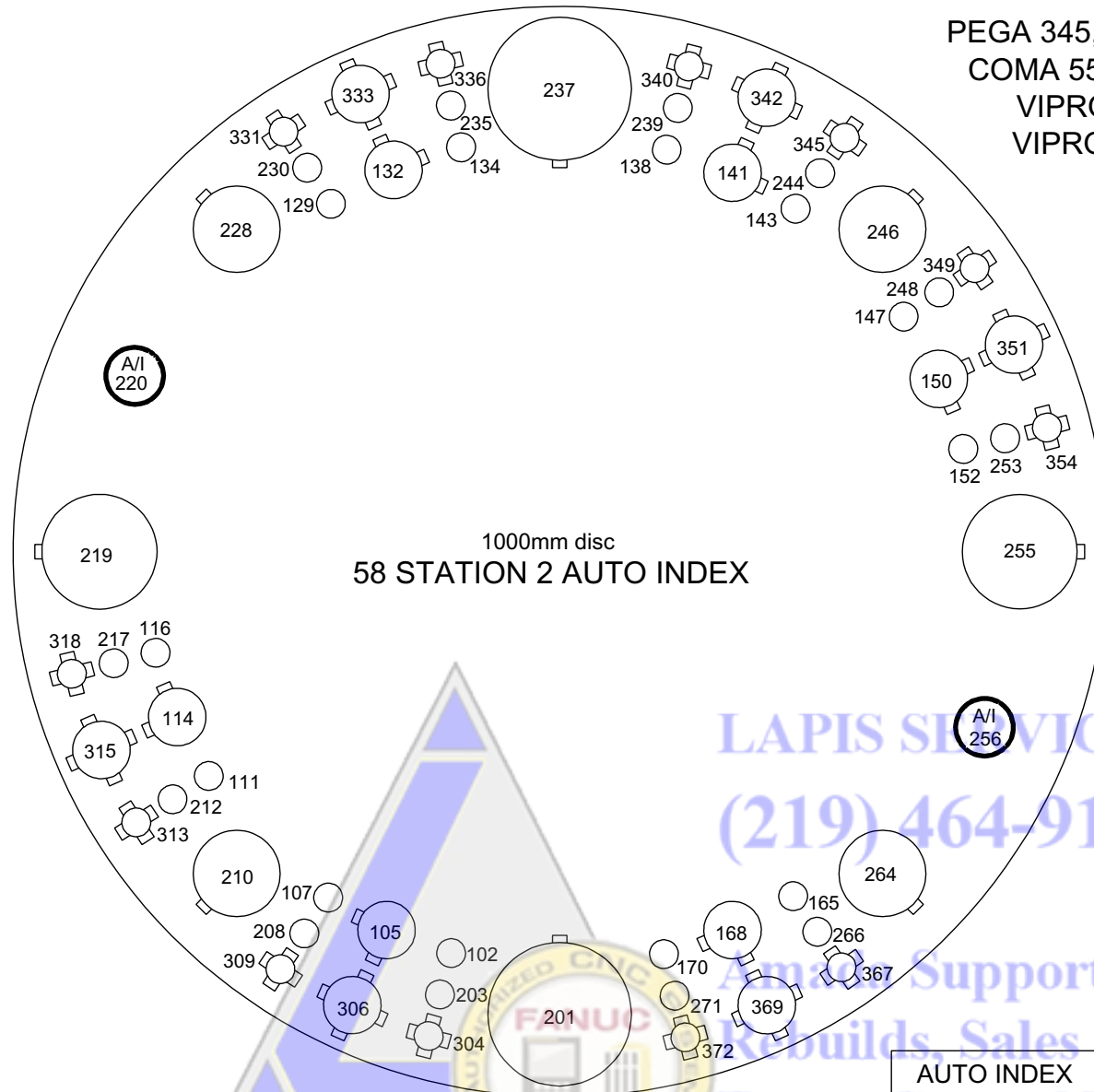

	MAXIMUM SIZE ROUND	NUMBER OF STATIONS (KEYED)
A	1/2" ( 12.7mm )	36 ( 12 )
B	1 1/4" ( 31.7mm )	12 ( 12 )
C	2" ( 50.8mm )	4 ( 4 )
D	3 1/2" ( 88.9mm )	2 ( 2 )
E	4 1/2" ( 114.3mm )	2 ( 2 )
AUTO INDEX	B 1 1/4" ( 31.7mm )	2 ( 2 )

## Specifications - Fanuc 18PC Controller

Model	Fanuc 18PC (with PHNC)
Control Function	X, Y, T & C
Input Method	MDI, 3½" Floppy, DNC
Minimum Command Unit	0.001" (X, Y) .01 <sup>0</sup> (C)
Minimum Travel Unit	0.001" (X, Y) .01 <sup>0</sup> (C)
Operating Modes	Automatic, MDI & Manual
Display Modes	Program Contents, Position Information, Program Check, Parameters, Tool Hit Counter, Self Diagnostics
Interlock Displays	Oil Temperature, Oil Pressure, Door Open

## Specifications - Hydraulic Systems

### Power Hydraulic Numerical Control

Ram Cycle Patterns	65 Total
	Punching           2
	Nibbling           1
	Forming            50
	Marking            4
	Knockouts         4
	Slitting            4
Minimum Increment	0.01mm

### Hydraulic Power Unit

Model	Yuken
Dual Operating Pressure	100 kgf cm <sup>2</sup> & 195 kgf cm <sup>2</sup>
Oil Type	Mobil DTE <sup>®</sup> Excel 46 (formerly called Mobil Hydraulic Oil NZ 46)
Oil Capacity	40 Gallons

LAPIS SERVICES  
(219) 464-9131

Amada Support,  
Rebuilds, Sales And  
Fanuc Control Upgrades.

LAPISINC.COM

## Supply Requirements - Electrical

Vipros 357 Queen	230 / 460 / 3 / 60 ±10%, 30 kVA 76 amps @ 230 / 3 / 60 VAC* 38 amps @ 460 / 3 / 60 VAC*
SBC EX 5.5 Chiller Chiller voltage must be specified when machine is ordered.	230 or 460 / 3 / 60 ±10%, 15 kVA 38 amps @ 230 / 3 / 60 VAC* 19 amps @ 460 / 3 / 60 VAC*

### Optional Equipment

V357hs Conveyor	208 / 230 / 460 3ph ±10%, kVA 2.1 amps @ 208 / 3 / 60 VAC* 2.0 amps @ 230 / 3 / 60 VAC* 1.0 amps @ 460 / 3 / 60 VAC*
MP1225 Loader	200 / 3 / 60 ±10%, 10 Kva 29 amps @ 200 / 3 / 60 VAC*  To operate at 230 / 460 VAC a step up transformer with the following service is required  26 amps @ 230 / 3 / 60 VAC* 13 amps @ 460 / 3 / 60 VAC*

\* The actual supplied electrical service must be sized to allow for starting current of approximately 150% of this value.



LAPIS SERVICES  
(219) 464-9131

Amada Support,  
Rebuilds, Sales And  
Fanuc Control Upgrades.

LAPISINC.COM

## Installing the Electrical Power Supply

The Vipros 357 Queen requires two separate electrical power sources. The first power source is supplied to the Fanuc 18PC. The other power source goes to the SBC EX 5.5 Chiller. The Vipros 357 Queen should be supplied from a power line separate from those for welding machines or other machines that produce electrical noise.

- ❑ The Vipros 357 Queen electrical inlet is 64" above floor level at the rear of the Fanuc 18PC control.
- ❑ The SBC EX 5.5 Chiller electrical inlet is approximately 53" above floor level.
- ❑ For the location of required electrical supplies for optional equipment, please see the installation guides for the specific equipment.

Vipros 357 Queen rear of electrical enclosure

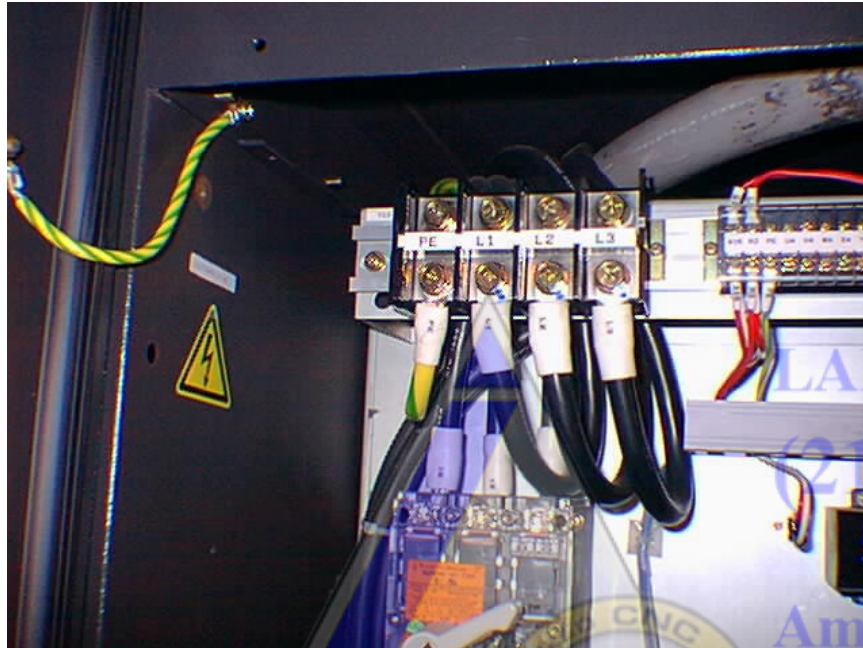

SBC EX 5.5 Chiller electrical enclosure

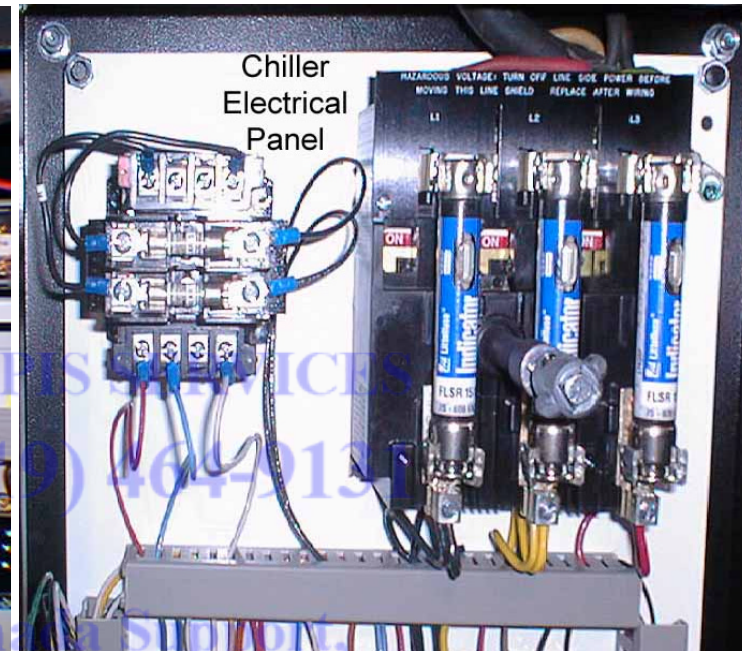

Rebuilds, Sales And  
Fanuc Control Upgrades.

LAPISINC.COM

## Supply Requirements - Pneumatic

Vipros 357 Queen	80 psi @ 8.8 ft <sup>3</sup> /min.
------------------	------------------------------------

### Optional Equipment

MP1225 Loader	75 psi @ 31.8 ft <sup>3</sup> /min.
---------------	-------------------------------------

### Installing the Pneumatic Supply

The Vipros 357 Queen requires connection to a compressed air system by hose or pipe. The compressed air must be clean and dry.

Please note the following:

- ❑ The minimum pipe inside diameter is ½".
- ❑ The air pressure required is 80 psi.
- ❑ The air volume required is 8.8 ft<sup>3</sup>/min..
- ❑ The air inlet is approximately 16" above the floor level at the rear of the Vipros 357 Queen

For the location of required air supplies for optional equipment, please see the installation guides for the specific equipment

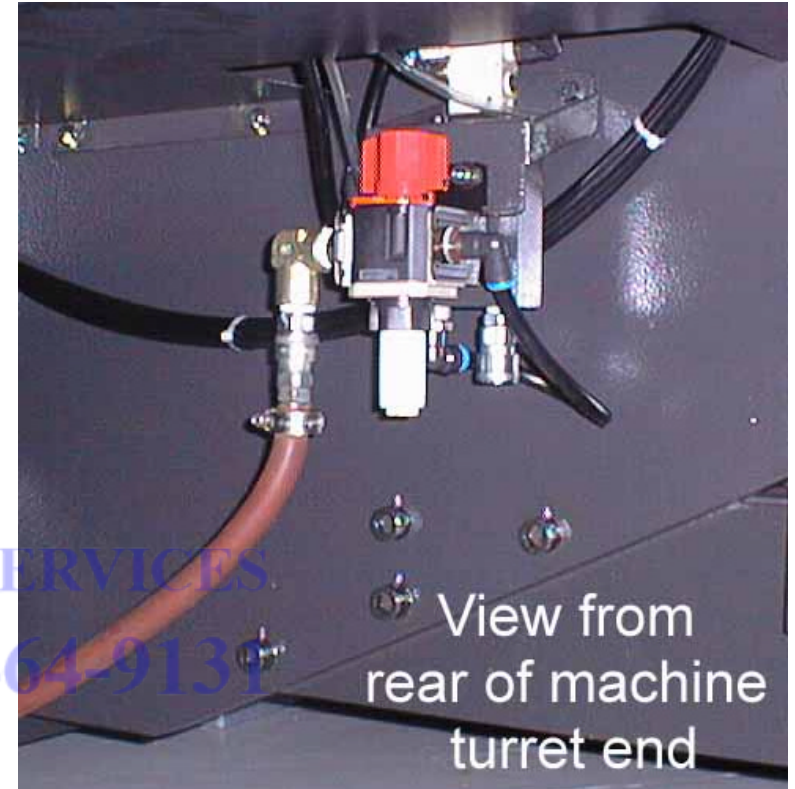

LAPIS SERVICES  
 (219) 464-9131  
 Amada Support,  
 Rebuilds, Sales And  
 Fanuc Control Upgrades.

LAPISINC.COM

## Planning the Location of the Vipros 357 Queen

The following diagrams provide the details for positioning the Vipros 357 Queen.

- ❑ No obstacles are allowed in the worksheet travel area and the ceiling must be at least 40" above the top of the Vipros 357 Queen.
- ❑ All of the recommended Safety / Maintenance areas should be used, but at a minimum, the doors of the Fanuc 18PC control must be able to be opened. Any reduction of the recommended Safety / Maintenance areas may decrease personnel safety and increase time and expense of installation and maintenance.
- ❑ The Vipros 357 Queen and Fanuc 18PC control must be protected from direct sunlight or other heat sources. Exposure to direct heating sources such as infrared heaters have been shown to affect punch and die alignment.
- ❑ The positioning of the SBC EX 5.5 Chiller is very flexible. See page 19, *SBC EX 5.5 Chiller*, for details.

### Moving the Vipros 357 Queen

Lifting or moving of the Vipros 357 Queen should be done only by professional rigging companies well versed in the moving of large and heavy industrial machinery. Acceptable moving methods include, lifting by overhead crane, wheeled dollies beneath the machine feet, or adequately sized lifttruck forks beneath the machine frame.

The Vipros 357 Queen has a relatively high center of gravity and narrow footprint. Care must be taken to prevent inadvertent tipping of the machine while in motion.

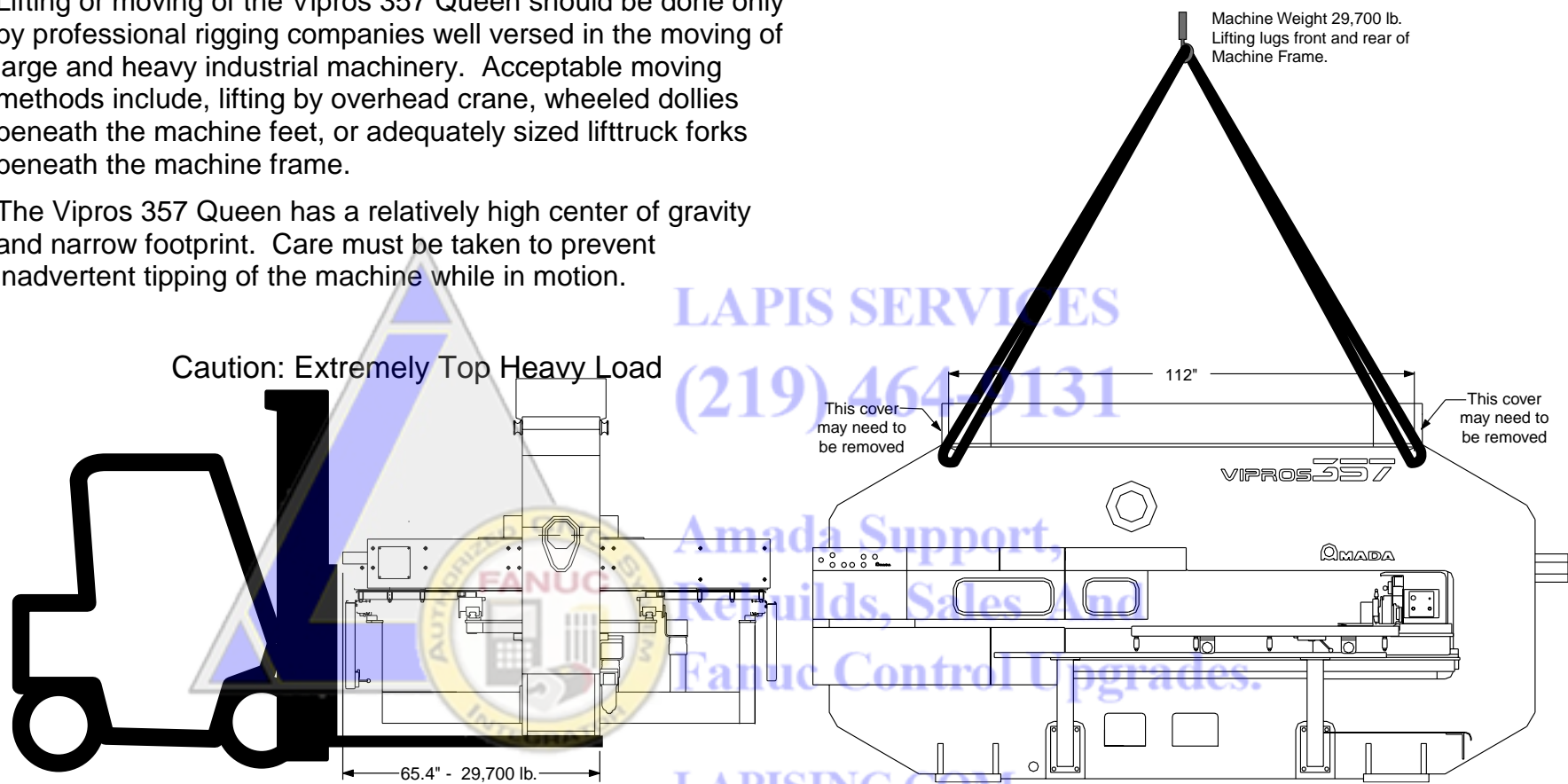

# Plan View - Vipros 357 Queen

Electrical Requirements	
(E1)	Vipros 357 Queen 230 / 460 / 3 / 60 ±10% 30 kVA 76 amps @ 230 / 3 / 60 VAC 38 amps @ 460 / 3 / 60 VAC
(E2)	SBC EX.5.5 Chiller 230 or 460 / 3 / 60 ±10% 15 kVA 37 amps @ 230 / 3 / 60 VAC 19 amps @ 460 / 3 / 60 VAC
Compressed Air Requirements	
(P1)	Vipros 357 Queen 80 psi @ 8.8 ft <sup>3</sup> /min.

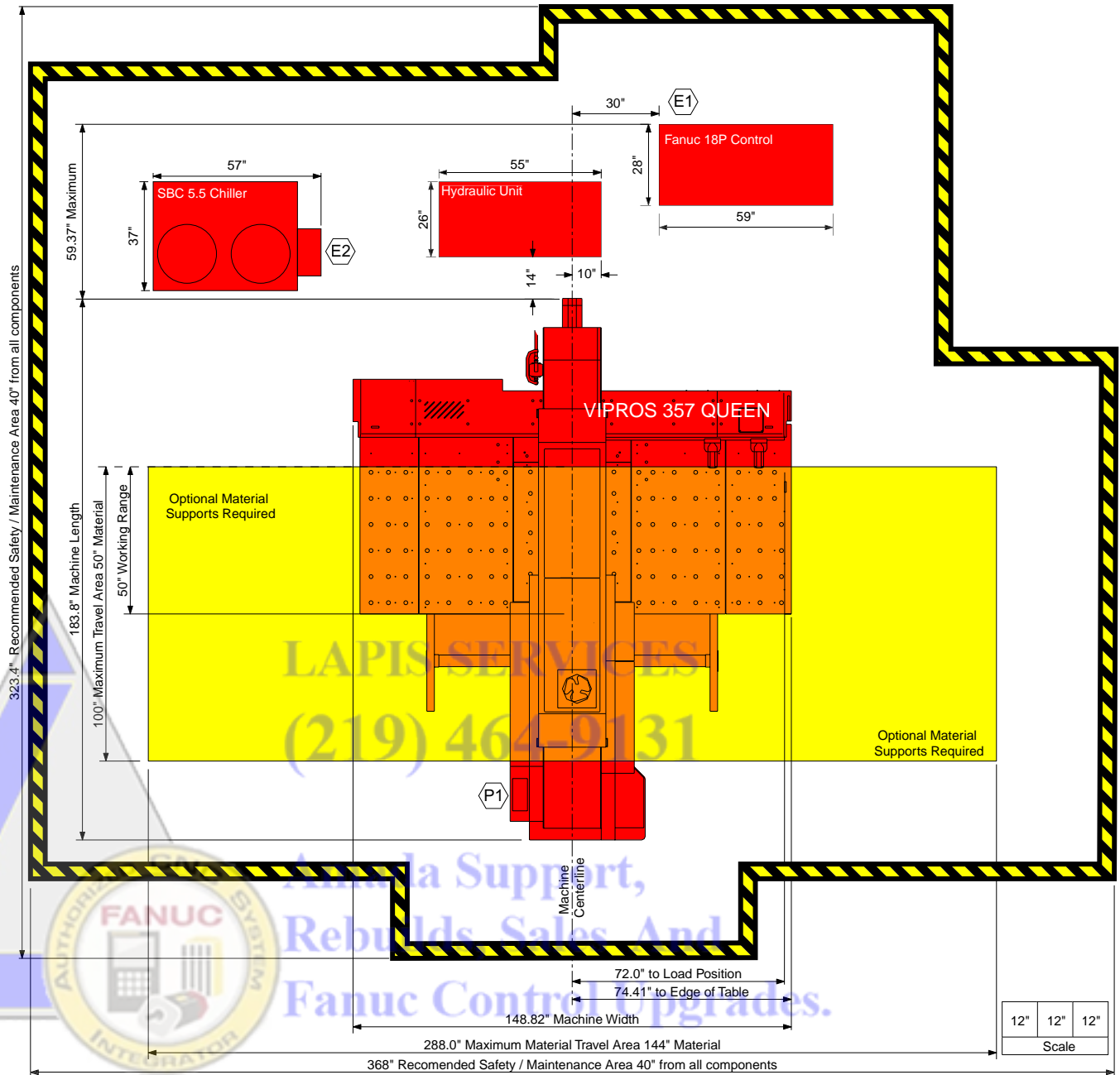

12"	12"	12"
Scale		

# Plan View - Vipros 357 Queen with V357hs conveyor

Electrical Requirements	
(E1)	Vipros 357 Queen 230 / 460 / 3 / 60 ±10% 30 kVA 76 amps @ 230 / 3 / 60 VAC 38 amps @ 460 / 3 / 60 VAC
(E2)	SBC EX5.5 Chiller 230 or 460 / 3 / 60 ±10% 15 kVA 37 amps @ 230 / 3 / 60 VAC 19 amps @ 460 / 3 / 60 VAC
(E3)	V357hs Conveyor 208 - 230 / 460 / 3 / 60 ±10% .8 kVA 2.1 amps @ 208 / 3 / 60 VAC 2.0 amps @ 230 / 3 / 60 VAC 1.0 amps @ 460 / 3 / 60 VAC
Compressed Air Requirements	
(P1)	Vipros 357 Queen 80 psi @ 8.8 ft <sup>3</sup> /min.

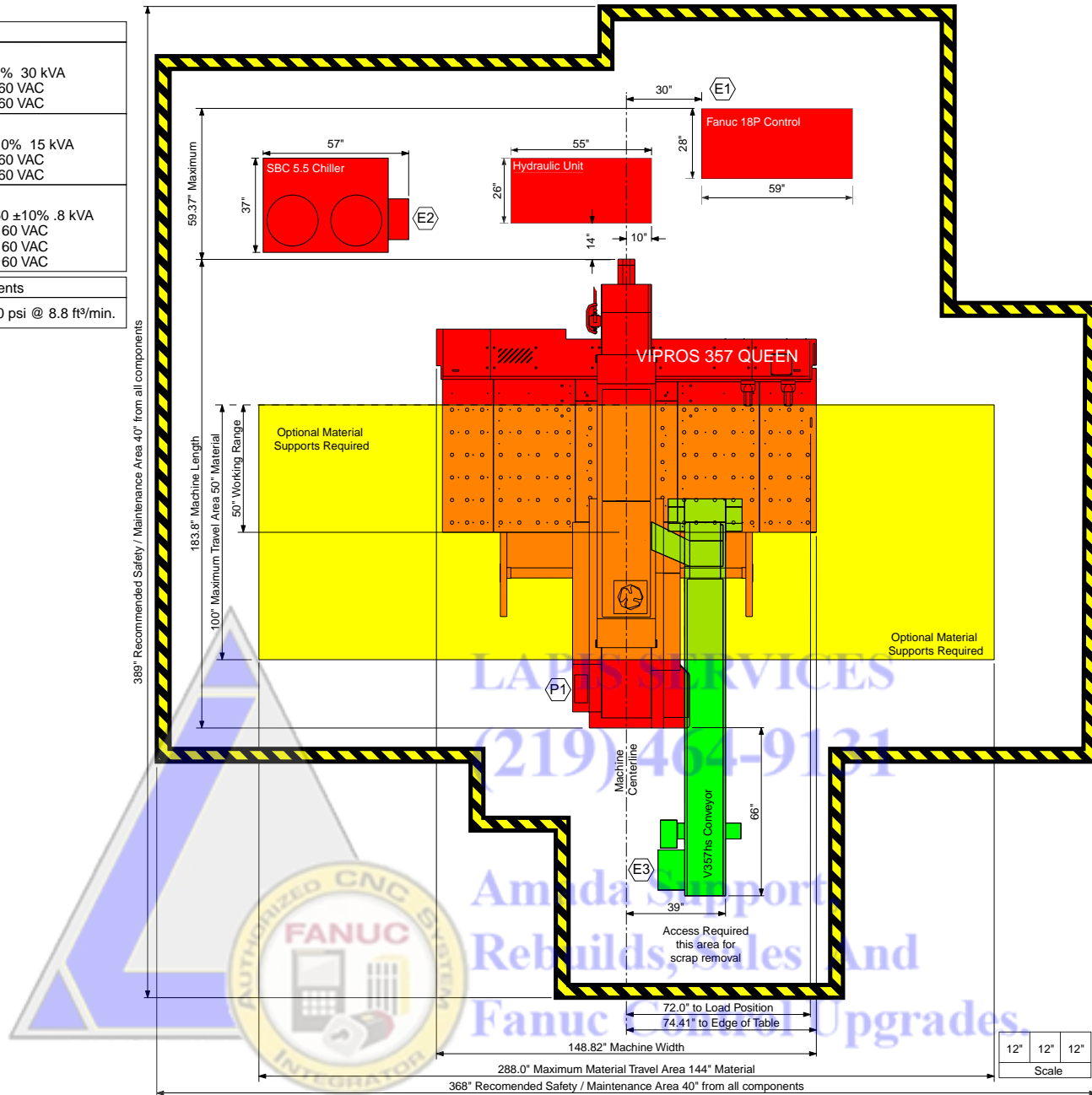

# Plan View - Vipros 357 Queen with V357hs conveyor and MP1225 loader

Electrical Requirements	
(E1)	Vipros 357 Queen 230 / 460 / 3 / 60 ±10% 30 kVA 76 amps @ 230 / 3 / 60 VAC 38 amps @ 460 / 3 / 60 VAC
(E2)	SBC EX5.5 Chiller 230 or 460 / 3 / 60 ±10% 15 kVA 37 amps @ 230 / 3 / 60 VAC 19 amps @ 460 / 3 / 60 VAC
(E3)	V357hs Conveyor 208 - 230 / 460 / 3 / 60 ±10% .8 kVA 2.1 amps @ 208 / 3 / 60 VAC 2.0 amps @ 230 / 3 / 60 VAC 1.0 amps @ 460 / 3 / 60 VAC
(E4)	MP1225 Loader 200 / 3 / 60 ±10%, 10 Kva To operate at 230 / 460 VAC a step up transformer with the following service is required 29 amps @ 200 / 3 / 60 VAC 26 amps @ 230 / 3 / 60 VAC 13 amps @ 460 / 3 / 60 VAC

Compressed Air Requirements	
(P1)	Vipros 357 Queen 80 psi @ 8.8 ft³/min.
(P2)	MP1225 Loader 75 psi @ 31.8 ft³/min.

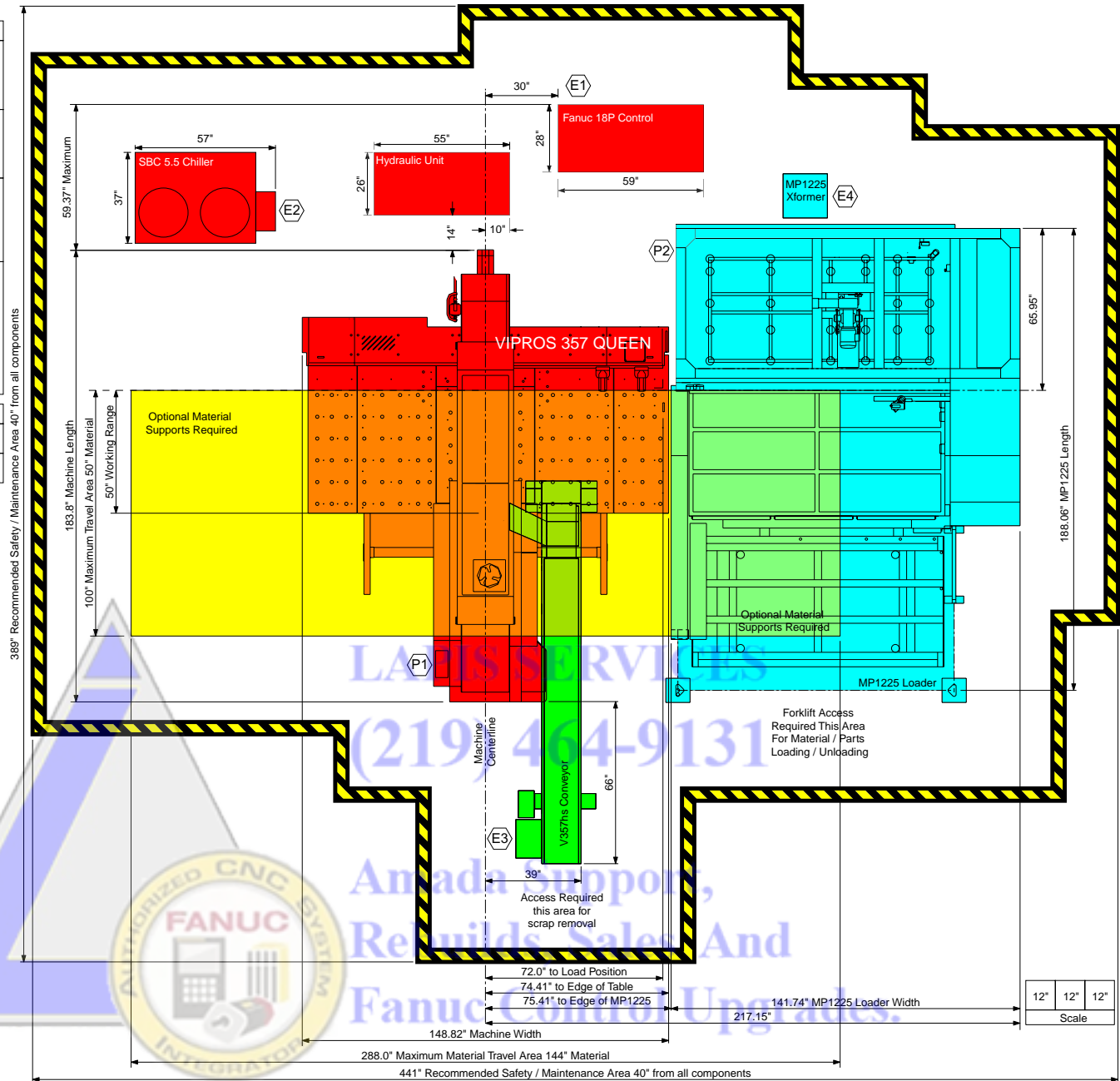

## End View - Vipros 357 Queen

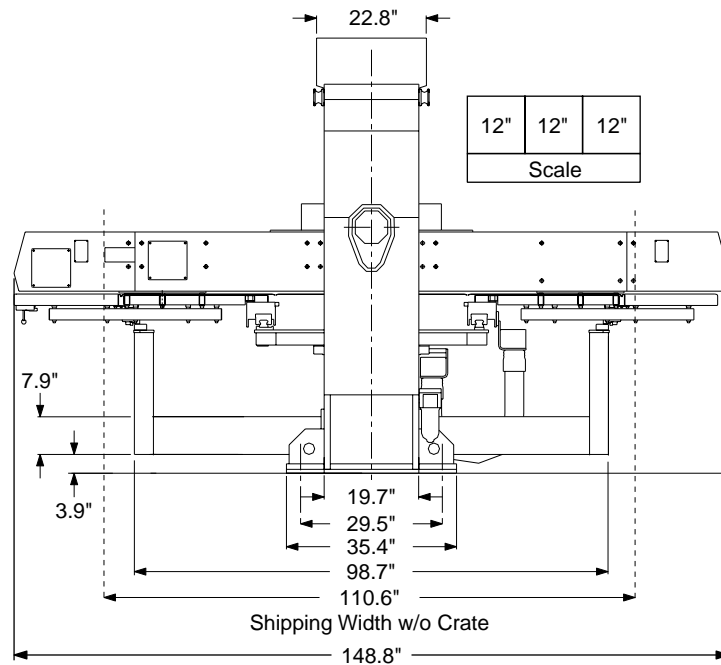

**LAPIS SERVICES**  
**(219) 464-9131**

**Amada Support,  
 Rebuilds, Sales And  
 Fanuc Control Upgrades.**

**LAPISINC.COM**

# Elevation View - Vipros 357 Queen

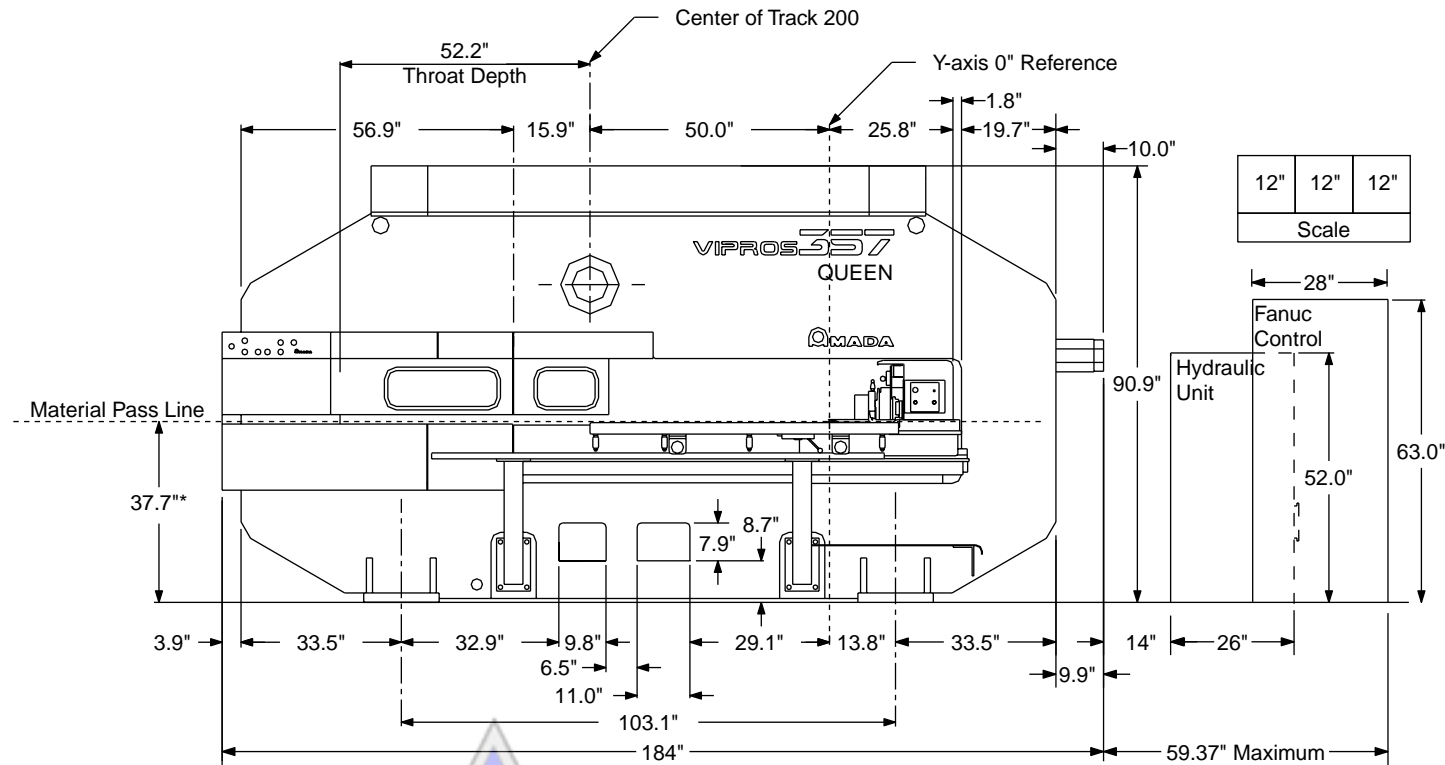

\*Material Pass Line will vary with installed options

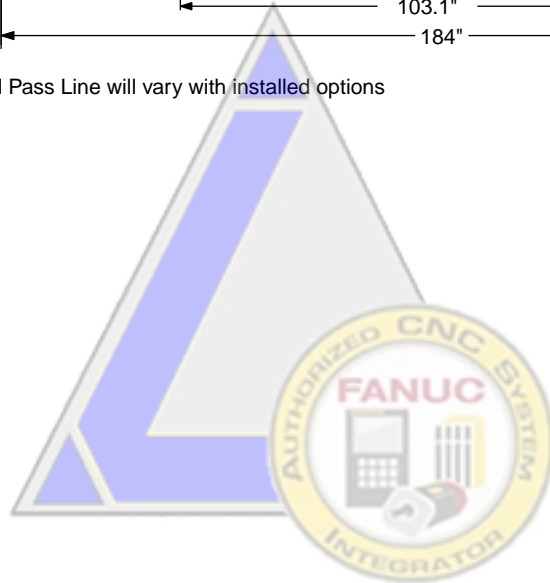

**LAPIS SERVICES**  
**(219) 464-9131**

**Amada Support,  
 Rebuilds, Sales And  
 Fanuc Control Upgrades.**

**LAPISINC.COM**

# SBC EX 5.5 Chiller

Model	SBC EX 5.5
Cooling Capacity	78,000 BTU/hour at 65 <sup>0</sup> ambient air temperature
Water Volume	10-15 GPM at 35 p.s.i.
Reservoir Capacity	60 Gallons (distilled water)
Pump HP	1 hp single phase

## SBC EX 5.5 Chiller Placement

The SBC EX 5.5 Chiller is very important to the reliable operation of the Vipros 357 Queen.

The SBC EX 5.5 Chiller must be placed so that an adequate flow of air is maintained.

The position of the SBC EX 5.5 Chiller is flexible. The SBC EX 5.5 Chiller is supplied with two (2) fifteen-foot lengths of hose to connect the to the Vipros 357 Queen Hydraulic Unit. The customer may supply a longer length of hose if required.

Under normal operating conditions the SBC EX 5.5 Chiller may be placed against walls as shown. However, for maintenance purposes access to all sides of the SBC EX 5.5 Chiller may be required.

The SBC EX 5.5 Chiller must have a minimum 60" of clearance above the SBC EX 5.5 Chiller for proper airflow.

Under normal operation the chiller may be placed against walls as shown. For maintenance access to all sides may be required. Chiller Location is shown for reference only.

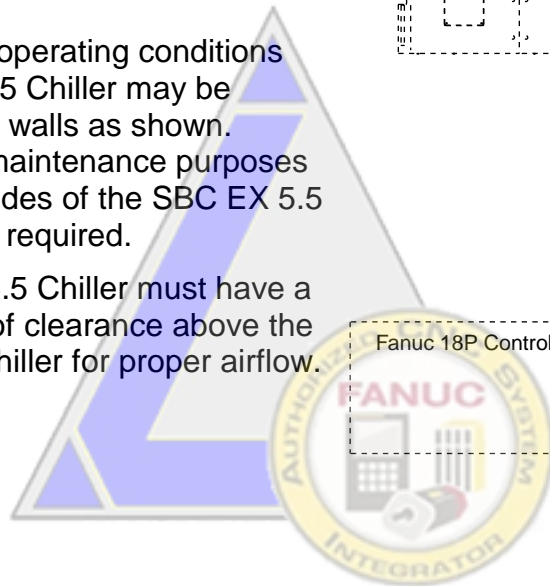
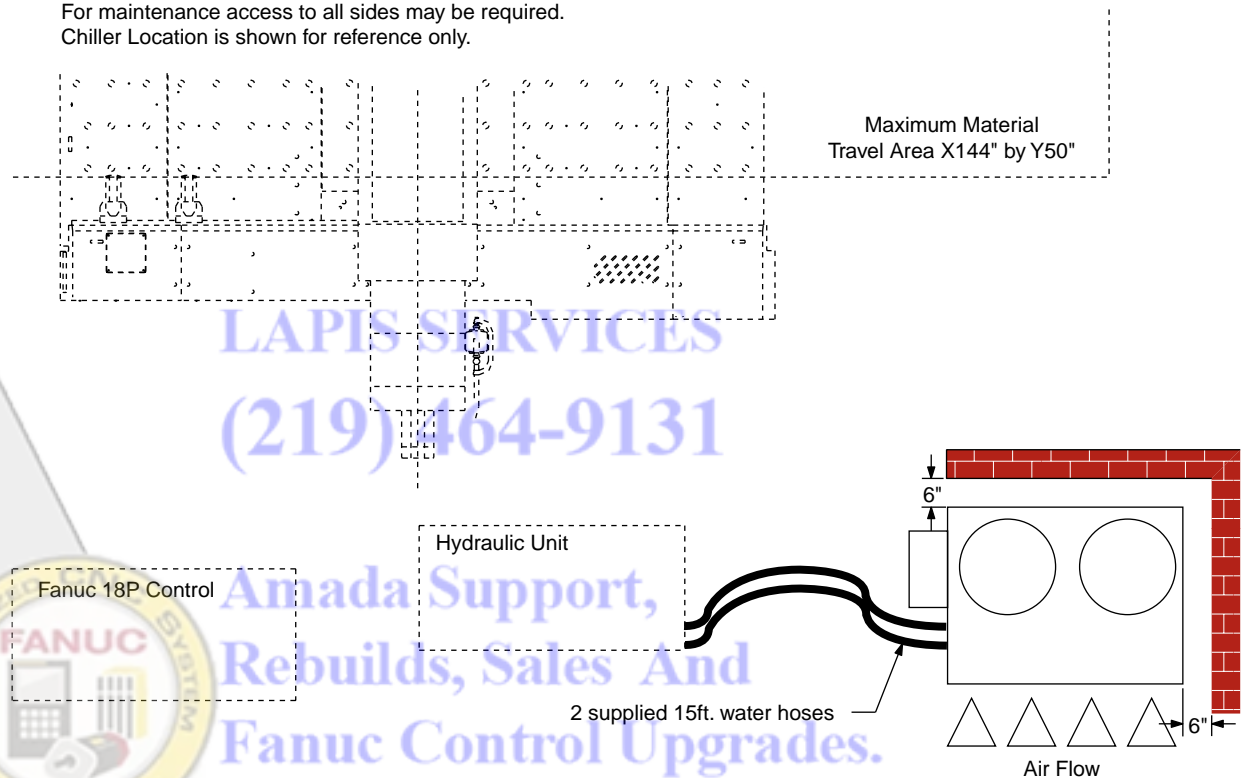

LAPIS SERVICES  
 (219) 464-9131  
 Amada Support,  
 Rebuilds, Sales And  
 Fanuc Control Upgrades.  
 LAPISINC.COM

# Chiller Connections

Vipros 357 Queen Hydraulic Unit

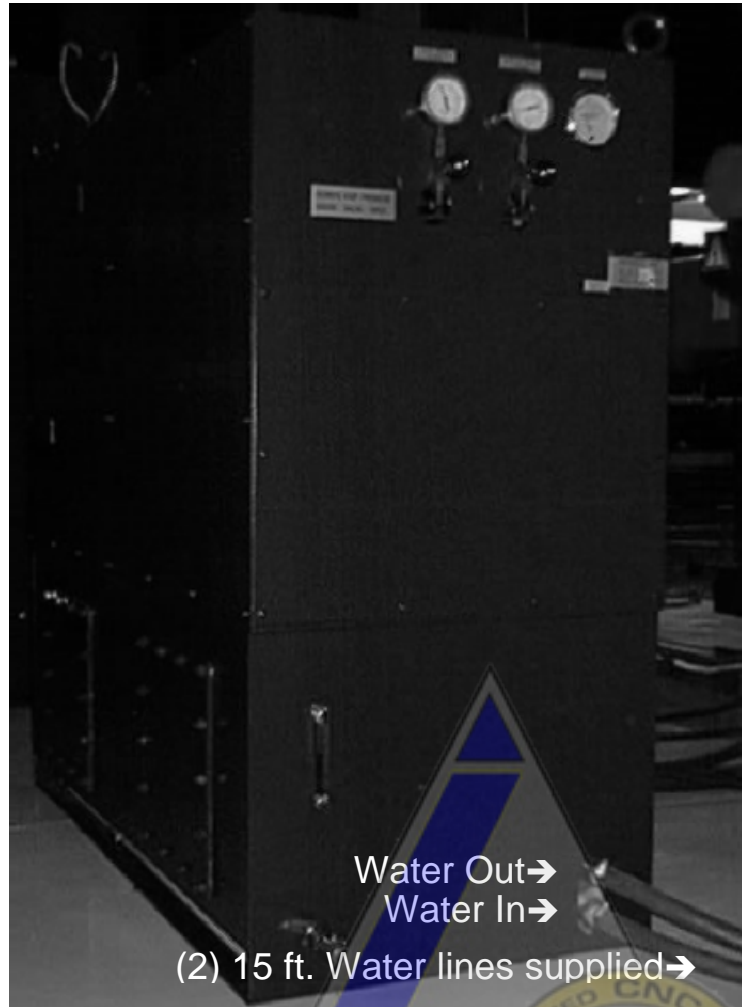

SBC EX 5.5 Chiller

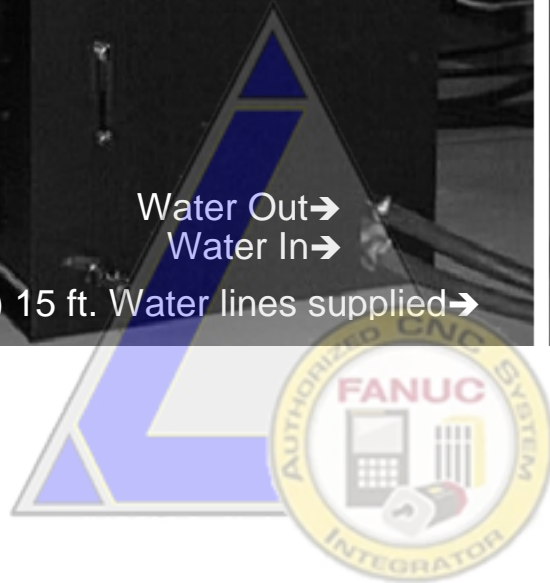
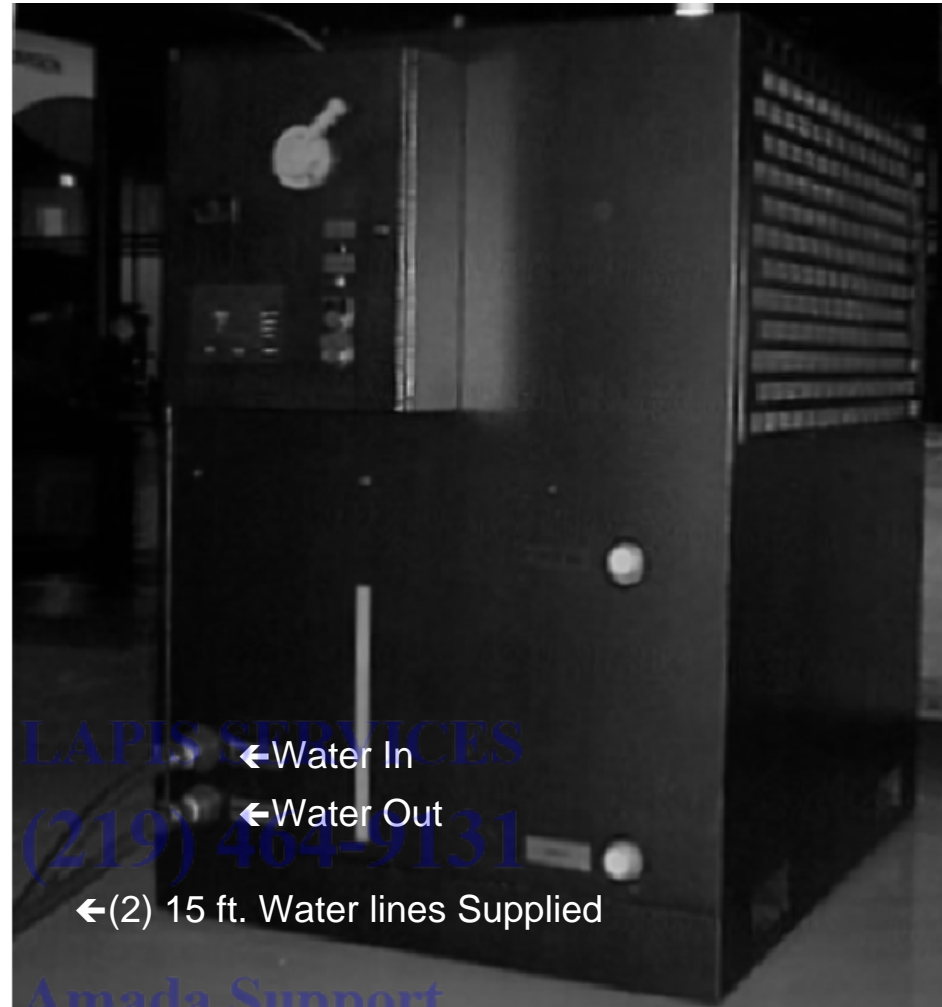

Amada Support,  
Rebuilds, Sales And  
Fanuc Control Upgrades.

LAPISINC.COM

## Foundation Requirements

The Vipros 357 Queen does not require a special foundation to perform as expected, however there are minimum requirements that an existing floor must meet in order to assure machine reliability and tool life. If the existing floor does not meet the following minimum requirements, plans for a recommended foundation are given on page 23, *Plan View - Foundation*.

The minimum acceptable floor conditions to assure a successful installation are:

- The area of the floor where the machine frame is to be located must be a single, homogeneous slab in good condition. There must be no cracks or other signs of deterioration of the floor.
- The floor must be 4" to 6" thick.
- The floor must be capable of supporting 3.5 tons/ft<sup>2</sup>.
- The floor must be level to 0.032"/ft.

If the existing floor meets the minimum requirement list above, it must still be inspected carefully when the anchor-bolt holes are cut. Voids under the floor, or wetness (not associated with the hole cutting procedure) should be considered signs of an inadequate floor and a new machine location or new foundation must be considered.

It is the customer's responsibility to determine that the floor meets these minimum requirements. Placing the machine on an inadequate, cracked floor, or straddling seams in a floor may be grounds for voiding the machine warranty!

Amada America Inc. does not recommend the use of vibration isolating mounts under the machine feet, as these devices have been shown to increase the vibration within the machine frame, increasing the likelihood of vibration related problems. Solid leveling devices are acceptable provided they incorporate a means of anchoring the machine to the floor with the supplied J-bolts or alternative anchoring method.

**Special Note:** This document details several methods of anchoring the Vipros 357 Queen to a new foundation or an existing floor. These methods are designed to install the Vipros 357 Queen as a stand-alone machine using the supplied anchor bolts and base plates. Installation or use of additional options such as leveling pads or material handling systems may dictate other methods of anchoring or foundation design not shown in this document. Before committing to a specific method of anchoring the Vipros 357 Queen, confirm that the chosen method is compatible with all purchased optional items and planned expansion.

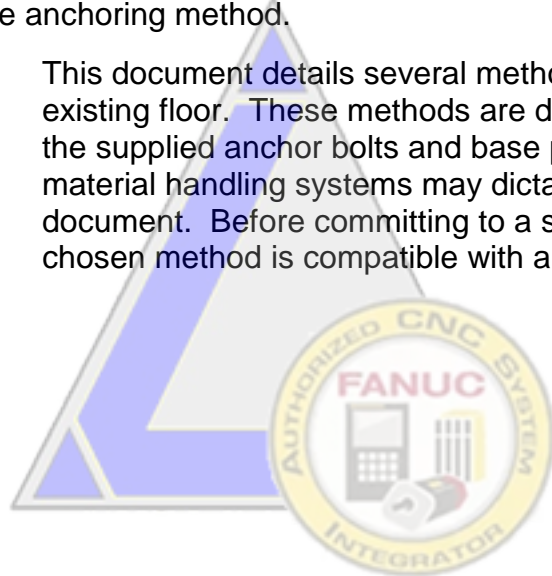

Amada Support,  
Rebuilds, Sales And  
Fanuc Control Upgrades.

LAPISINC.COM

# Foundation Anchoring Procedure

An ideal foundation is given on the following pages. This foundation must be used if the existing floor cannot meet the minimum requirements to support the machine.

The foundation must consist of a single, homogeneous slab. The foundation must be level to within 0.032" / ft. Anchoring the Vipros 357 Queen to the floor using the anchor-bolts supplied is essential to ensure reliable performance. Amada generally recommends that the foundation have a minimum load bearing capacity of 3.5 ton/ft<sup>2</sup>. It is the purchaser's responsibility to determine that the foundation meets these requirements.

Please note the following:

- The base plates, shims, anchor bolts, nuts, and washers are shipped with the Vipros 357 Queen.
- The concrete J-bolt pads should be filled after the machine is placed on the foundation.
- See special note page 21

## Foundation J-bolt Detail

See page 26, *Foundation / Floor J-bolt Mounting Procedure*, for proper method of mounting the Vipros 357 Queen on the foundation.

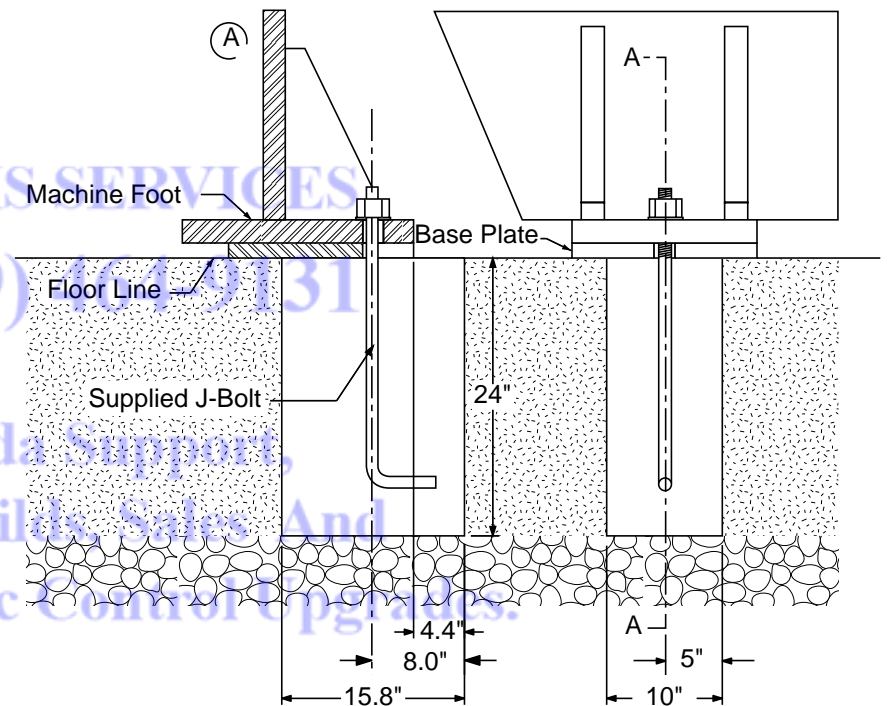
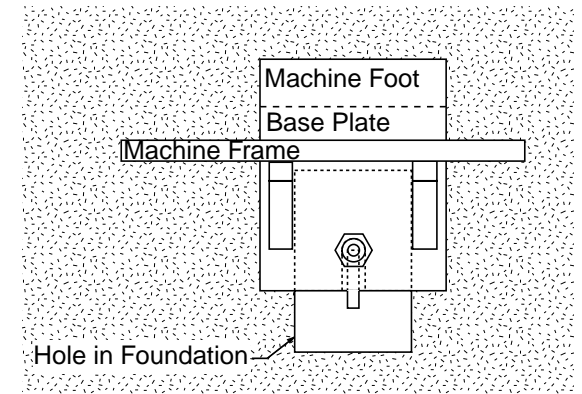

LAPIS SERVICES  
 (219) 404-9131  
 Amada Support, Rebuild, Sales And Fanuc Control Upgrades.  
 LAPISINC.COM

## Plan View - Foundation Vipros 357 Queen

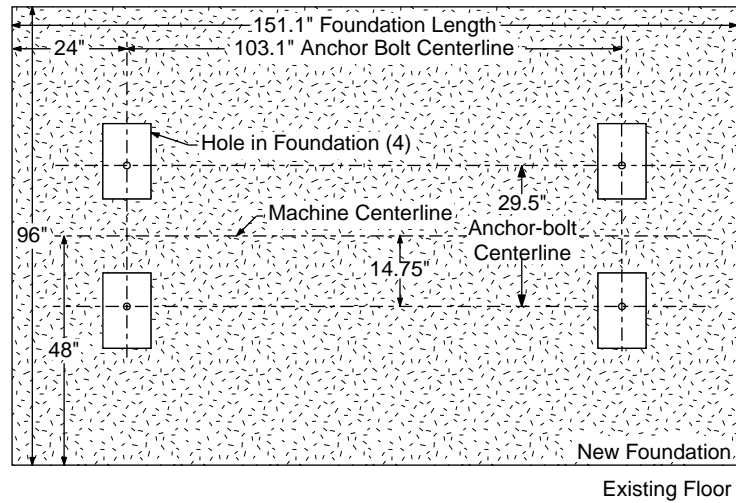

## Elevation - Foundation Vipros 357 Queen

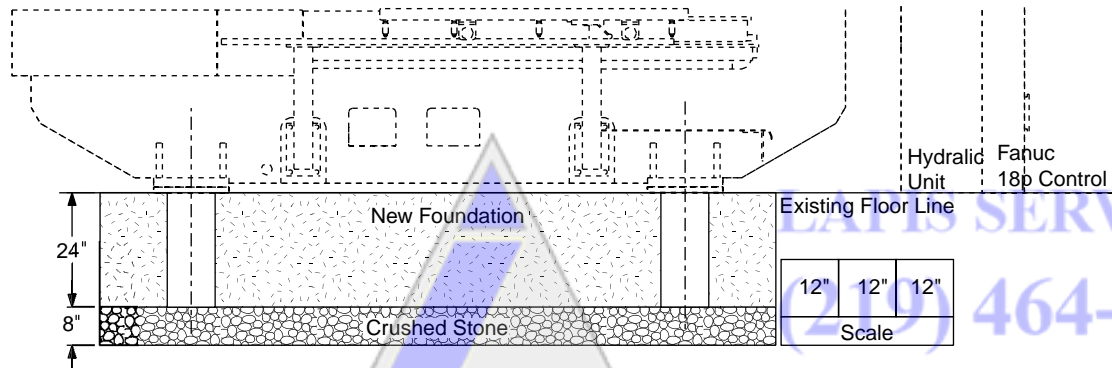

LAPIS SERVICES  
(219) 464-9131



Amada Support,  
Rebuilds, Sales And  
Fanuc Control Upgrades.

LAPISINC.COM

# Machine Anchoring Requirements Vipros 357 Queen

To maintain machine reliability, extend tool life, and remain level over an extended period the Vipros 357 Queen must be anchored in place on an adequate floor or foundation.

At a minimum the floor must consist of a single, homogeneous slab, level to within 0.032"/ft<sup>2</sup>, and capable of supporting 3.5 tons/ft<sup>2</sup>. It is the purchaser's responsibility to determine that the floor meets these minimum requirements.

## Floor J-bolt Mounting Hole Detail (saw cut hole)

This machine mounting method should be used only if the floor is of such quality that it will support the weight of the machine with the anchor J-bolts used only for maintaining the location of the machine.

See special note page 21

## Plan - Floor J-bolt Mounting Hole (saw cut hole)

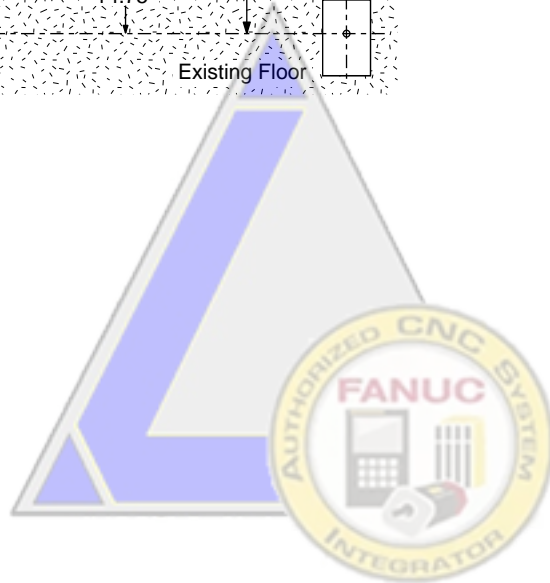
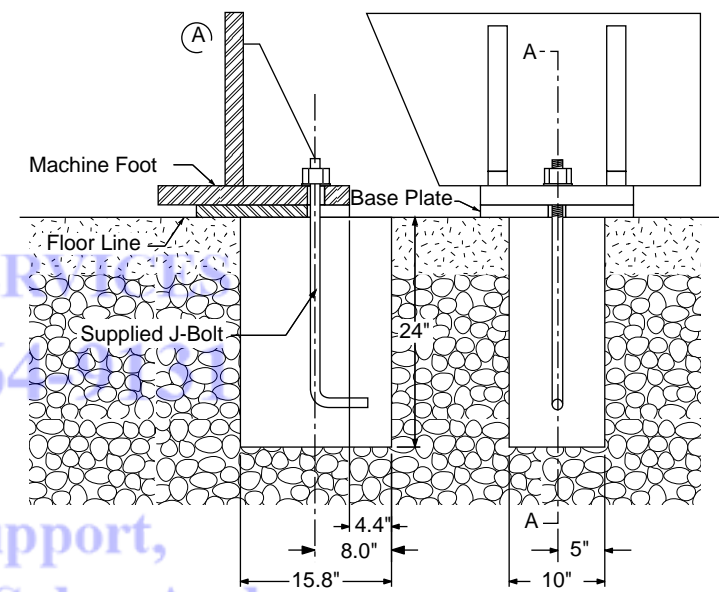
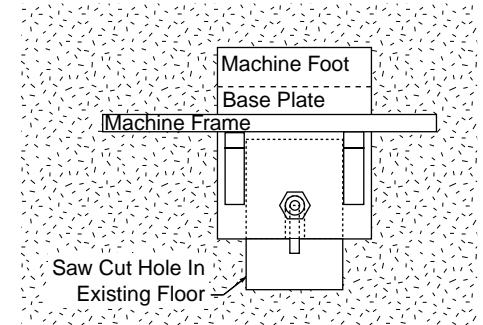
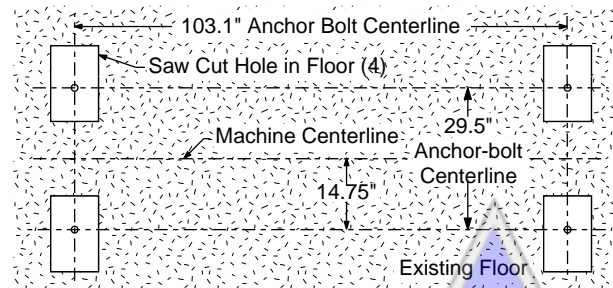

LAPIS SERVICES  
 (219) 464-XXXX  
 Amada Support,  
 Rebuilds, Sales And  
 Fanuc Control Upgrades.

LAPISINC.COM

## Alternative Floor J-bolt Mounting Hole Detail (Core Drill)

This machine mounting method should only be used if the floor is of such quality that it will support the weight of the machine with the anchor J-bolts used only for maintaining the location of the machine.

See special note page 21

### Plan - J-bolt Mounting Hole (Core Drill)

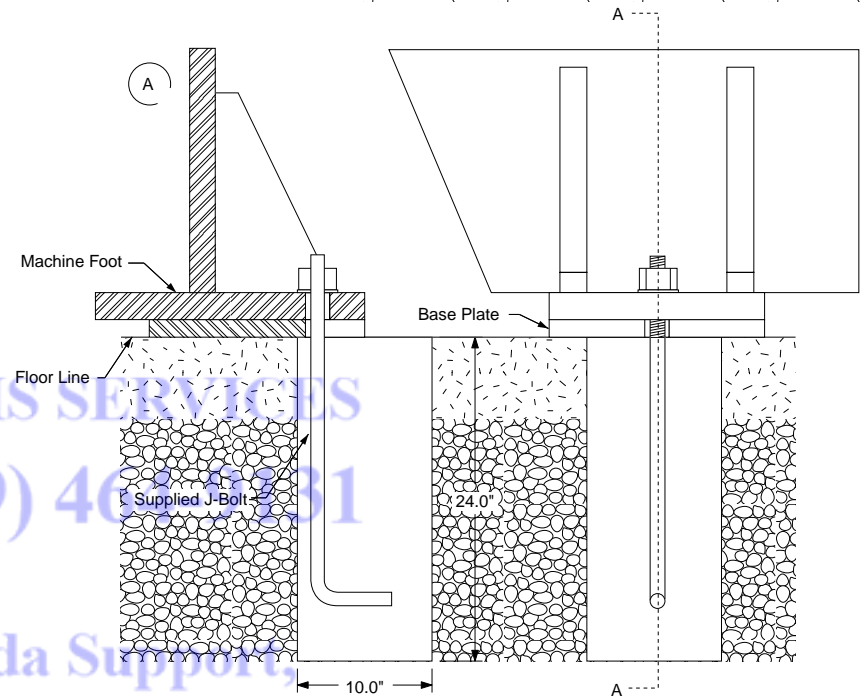
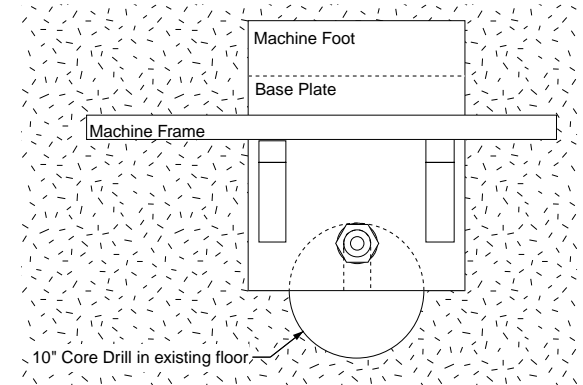
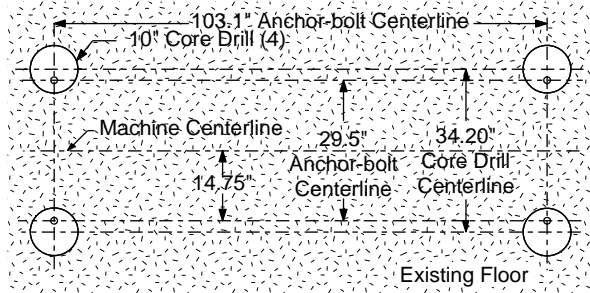

LAPIS SERVICES  
 (219) 464-1331  
 Amada Support,  
 Rebuilds, Sales And  
 Fanuc Control Upgrades.

LAPISINC.COM

## Foundation / Floor J-bolt Mounting Procedure

Step 1. Saw cut or Core drill a hole in the existing floor and remove the underlying dirt to the required 24" depth.

See Floor J-bolt Mounting Hole Plan View (saw cut hole) or Alternative J-bolt Mounting Method Plan View (Core Drill) for correct layout dimensions of the four anchor holes required.

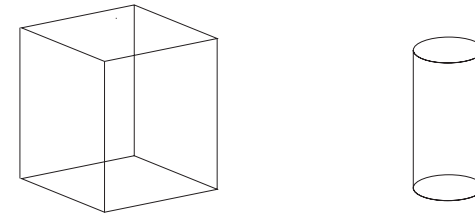

Step 2. Set base plate over the hole.

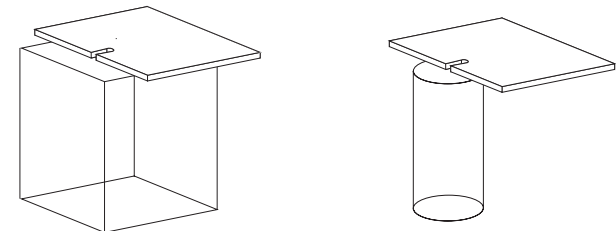

Step 3. Set the machine on the base plate.

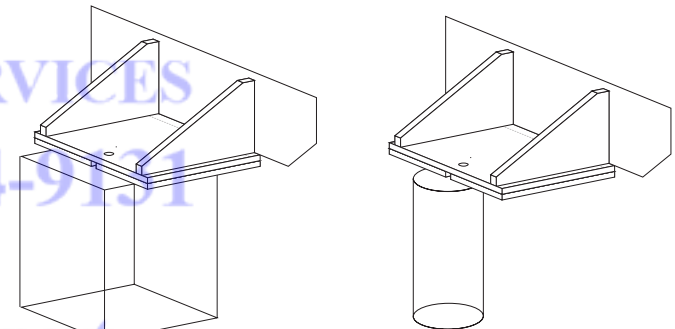

LAPIS SERVICES  
 (219) 464-9131  
 Amada Support,  
 Rebuilds, Sales And  
 Fanuc Control Upgrades.

LAPISINC.COM

Step 4. Set the J-bolt through the hole in machine foot, attach washer and nut to hold J-bolt in place.

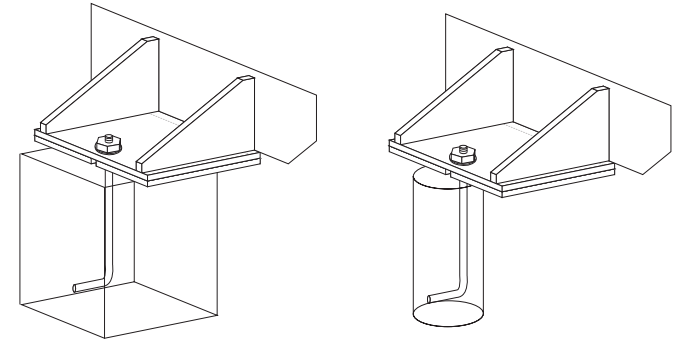

Step 5 Pour the Concrete.  
 Ensure that the J-bolt remains correctly aligned to the machine frame during the pouring and hardening time of the concrete.  
 Ensure that the concrete level is equal to the floor level

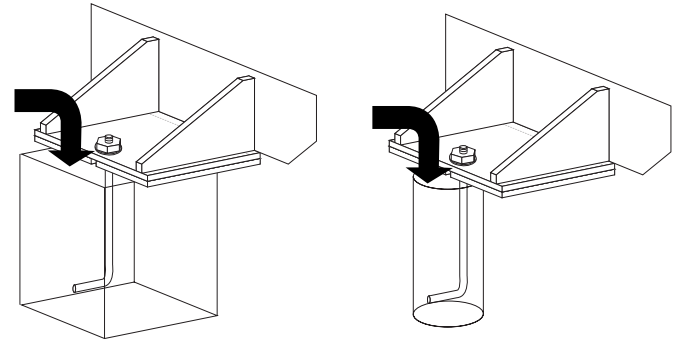

Step 6. To complete the mounting procedure, level the machine frame by inserting leveling shims between the machine foot and base plate.

See *Leveling the Machine* section for correct procedure.

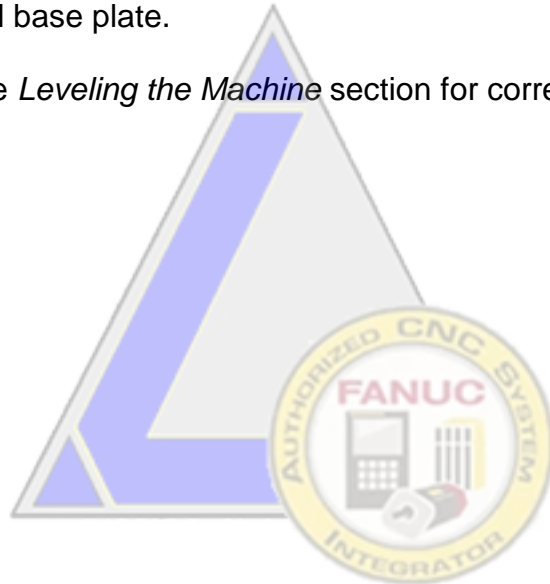
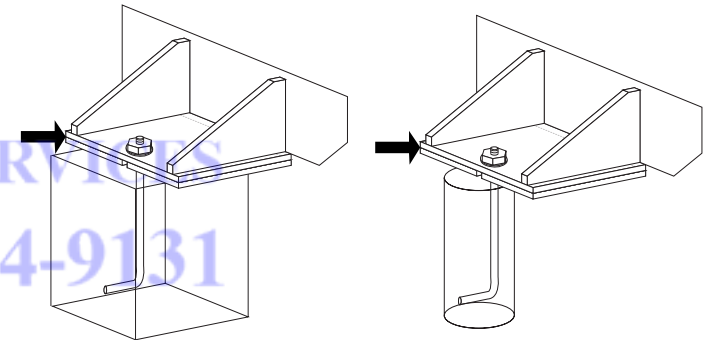

LAPIS SERVICES  
 (219) 464-9131  
 Amada Support,  
 Rebuilds, Sales And  
 Fanuc Control Upgrades.

LAPISINC.COM

## Alternative Anchoring Method (Drilled Hole with Anchor Rod and Adhesive)

This machine mounting method should only be used if the floor is of such quality that it will support the weight of the machine with the Anchor Rod used only for maintaining the location of the machine.

See special note page 21

### Plan - J-bolt Mounting Hole (Drilled Hole with Anchor Rod and Adhesive)

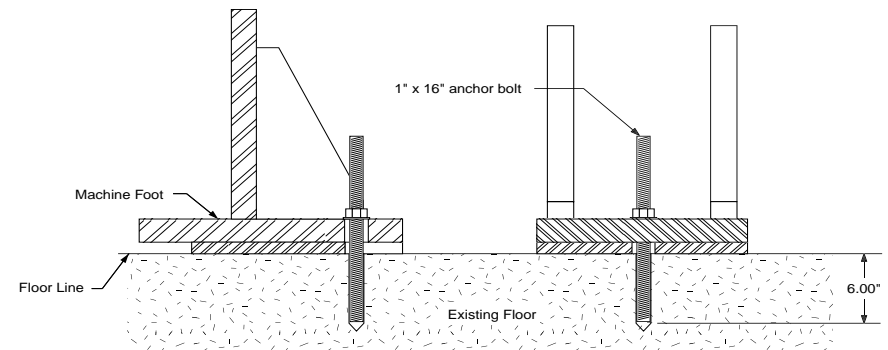
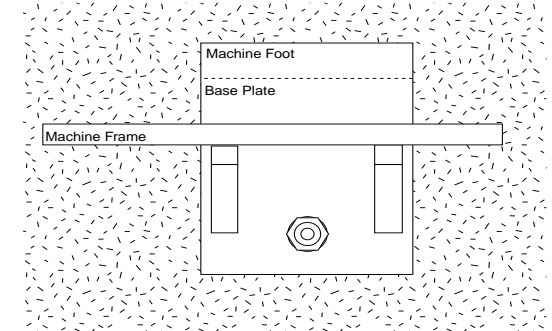
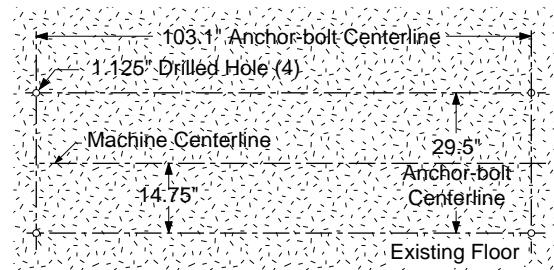

**LAPIS SERVICES**  
**(219) 464-9131**

**Amada Support,  
Rebuilds, Sales And  
Fanuc Control Upgrades.**

**LAPISINC.COM**

## Drilled Hole with Anchor Rod and Adhesive Mounting Procedure

- Step 1. Drill the four Anchor Rod holes in the existing floor.  
The holes should be drilled approximately 6" deep.  
See Alternative Floor Bolt Mounting Method Plan View (Drilled Hole with Adhesive Anchor Rod) for correct layout dimensions.

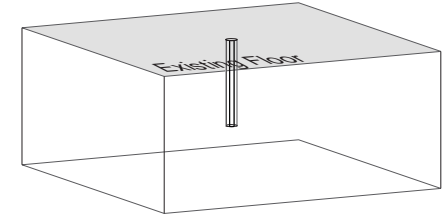

- Step 2. Set the Amada Machine Leveling Plates over the drilled holes

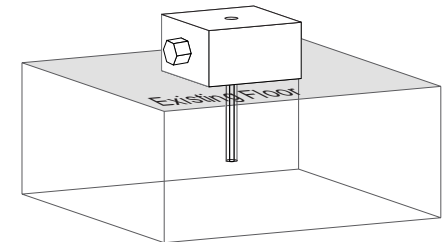

- Step 3. Set the machine on the machine leveling plates.  
Step 4. Level the machine frame by adjusting the Amada machine leveling plates.  
See *Leveling the Machine* section for correct procedure.

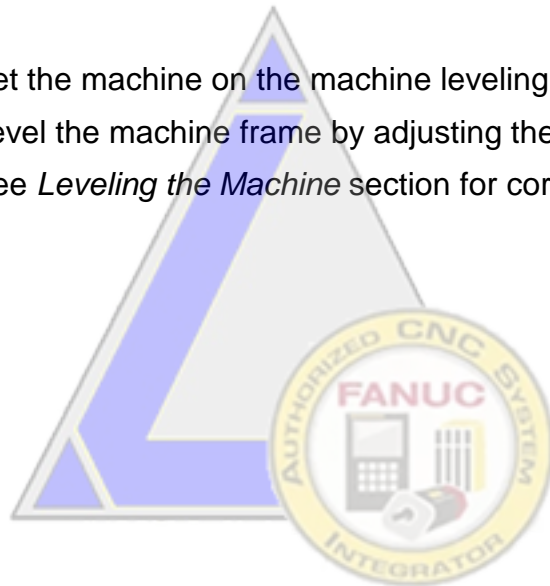
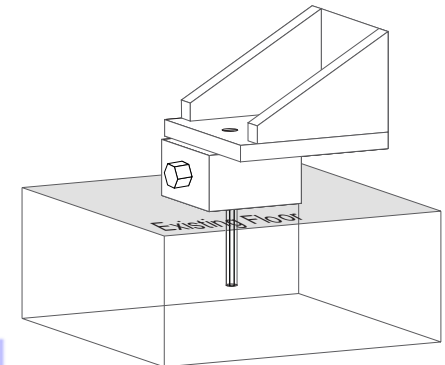

LAPIS SERVICES  
(219) 464-9131  
Amada Support,  
Rebuilds, Sales And  
Fanuc Control Upgrades.

LAPISINC.COM

**Step 5** Fill each of the Anchor Rod holes to within 2 inches of the floor surface with the Adhesive compound. Do not overfill.

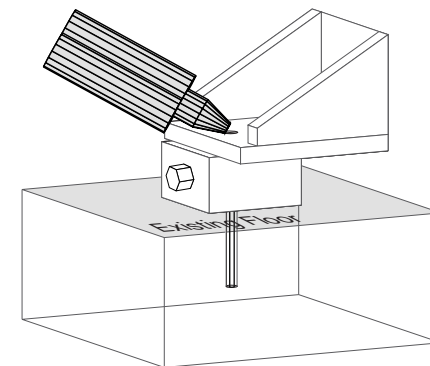

**Step 6** Attach the hex nut and flat washer on the Anchor Rod and place the Anchor Rod into the drilled hole.

Using a twisting motion to move the Anchor Rod through the epoxy compound, seat the flat washer and hex nut against the top of the machine foot.

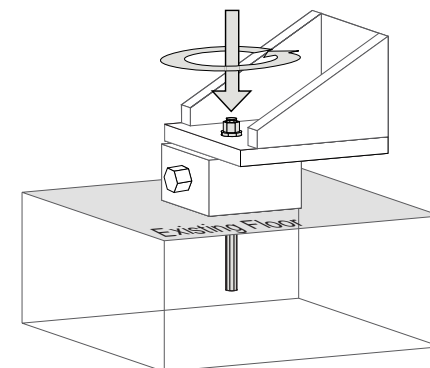

**Step 7** Allow the Adhesive to harden for 24 hours.

**Step 8.** Tighten the 4 hex nuts.

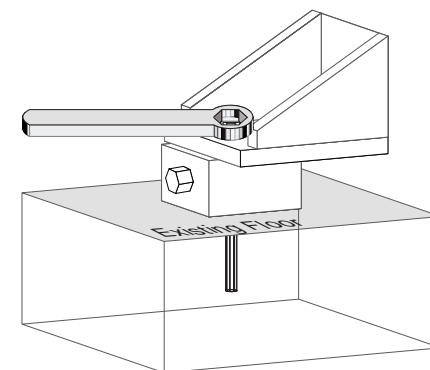

**LAPIS SERVICES**  
**(219) 464-9131**

**Amada Support,  
Rebuilds, Sales And  
Fanuc Control Upgrades.**

**LAPISINC.COM**

## Removing the Protective Coating

The Vipros 357 Queen must be thoroughly cleaned of protective coating. The sheet metal guards can be removed from around the turret to allow cleaning of the upper and lower turrets, tool bores and die holders.

Please note the following:

- ❑ Remove wrapping paper from the X and Y-axes ball screws, then remove the protective coating.
- ❑ Remove the wrapping paper from the X and Y LM guides then remove the protective coating, make sure that you remove the paper from both sides of the carriage.
- ❑ Clean die holders one at a time. Remove a die holder, clean and replace it before removing the next die holder. If the die holders are mixed up, serious turret alignment problems may occur.
- ❑ A suitable solvent should be used to remove the protective coating.

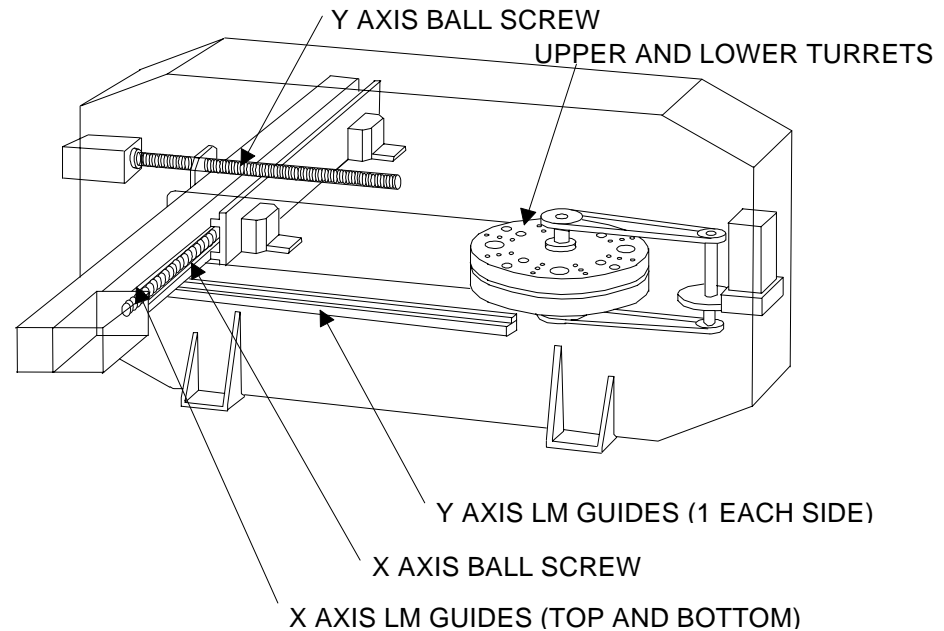

**LAPIS SERVICES**  
**(219) 464-9131**

**Amada Support,  
Rebuilds, Sales And  
Fanuc Control Upgrades.**

**LAPISINC.COM**

## Machine Leveling

Proper Machine leveling is critical to the Vipros 357 Queen performing as designed.

Materials and tools required:

Supplied with the machine:

Assorted thickness machine leveling shim stock

Anchor bolts

Supplied by AESI service:

Spirit level capable of reading 0.0005"/ft

One (1) 12 ton hydraulic bottle jack

Not supplied:

Additional shim stock of 0.005" thickness may be required to achieve a properly leveled machine.

## Rocking Test

After the machine frame has been leveled the use of the following G-code is necessary to determine that the machine frame is properly leveled and balanced.

Should the machine frame vibrate or move excessively during the rocking test the machine frame must be re-leveled using the procedure in this manual.

Should the proper leveling technique not eliminate the excessive frame motion, consideration must be given to relocation of the machine or replacement of the existing floor with an adequate foundation.

Set M500 values to Top Position 0.080", Bottom Position, 0.080", Slow Position 0.000"  
Repeat test with X-axis movement values of 0.500", 1.000", and 4.000"

G92X72.000Y50.000

G06A.100B0

M500

N1

G91G70X-.25Tttt(Use any valid tool number)

G70X.25

M97P1

G50

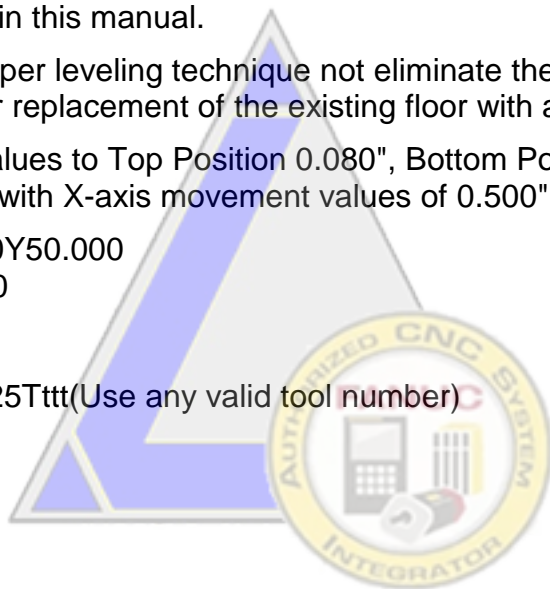

Amada Support,  
Rebuilds, Sales And  
Fanuc Control Upgrades.

LAPISINC.COM

## Floor Condition: Crowned

The flatness of the floor plays an important step in the leveling procedure of the machine. To properly level the machine the weight bearing points must be as far from the centerline of the machine frame as possible.

Should a condition known as crowning exist the weight bearing points of the machine may not be far enough from the machine centerline to ensure a stable machine.

Under these conditions, a procedure known as *Half-Shimming* should be used.

To move the weight bearing points further from the machine centerline the use of half-shims of .125" thick on top of the base plate as shown is recommended.

After the half-shims are installed and the machine frame is leveled, use the rocking test to determine that the machine frame is stable enough to allow production without damaging the machine.

Under extreme conditions the use of half-shims may not move the machine weight bearing points far enough from the machine centerline to ensure the machine frame is stable.

Under these conditions, a more suitable location must be found for the machine, or a new foundation for the machine will be necessary.

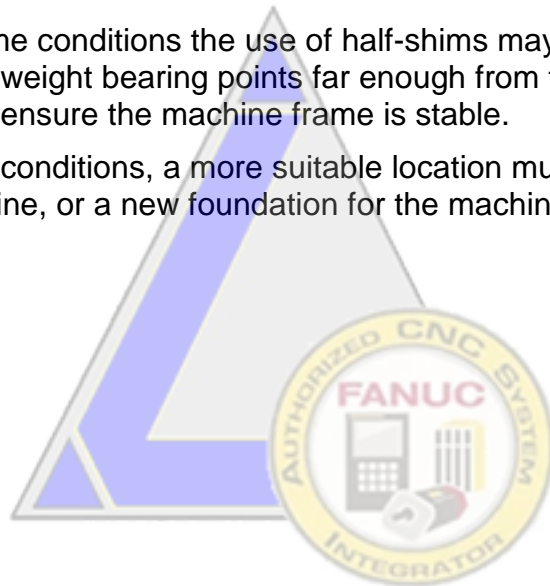
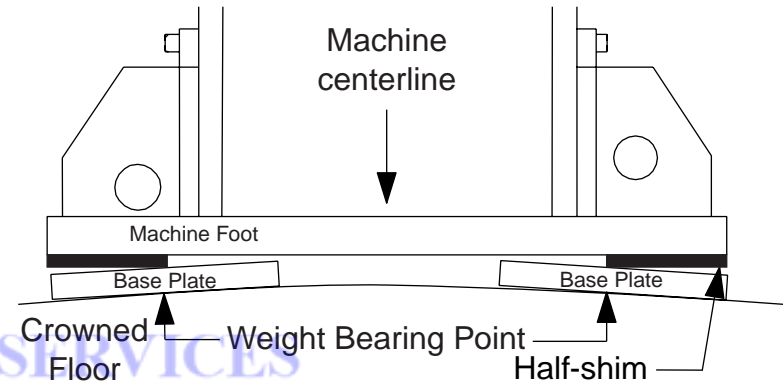
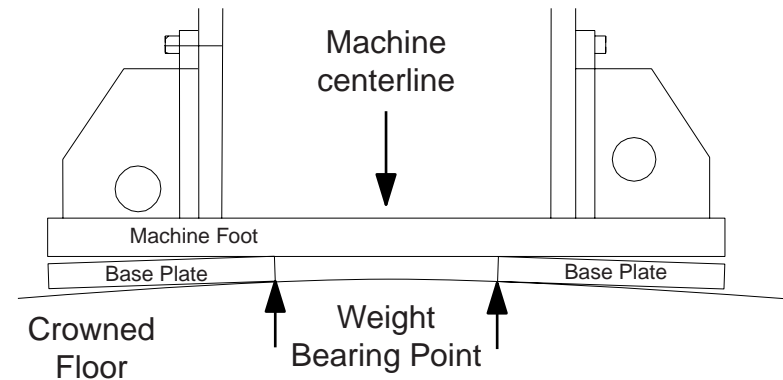

LAPIS SERVICES  
 (219) 464-9131  
 Amada Support,  
 Rebuilds, Sales And  
 Fanuc Control Upgrades.

LAPISINC.COM

## Floor Condition: Sloped

The slope of the floor plays an important step in the leveling procedure of the machine. To properly level the machine the weight bearing points must be as far from the centerline of the machine frame as possible.

Should the floor slope excessively the weight bearing points of the machine may not be far enough from the machine centerline to ensure a stable machine.

Under these conditions, a procedure known as *Half-Shimming* should be used.

To move the weight bearing points further from the machine centerline the use of half-shims of .125" thick on top of the base plate and leveling shims as shown is recommended.

After the half-shims are installed and the machine frame is leveled, use the rocking test to determine that the machine frame is stable enough to allow production without damaging the machine.

Under extreme conditions the use of half-shims may not move the machine weight bearing points far enough from the machine centerline to ensure the machine frame is stable.

Under these conditions a more suitable location must be found for the machine, or a new foundation for the machine will be necessary.

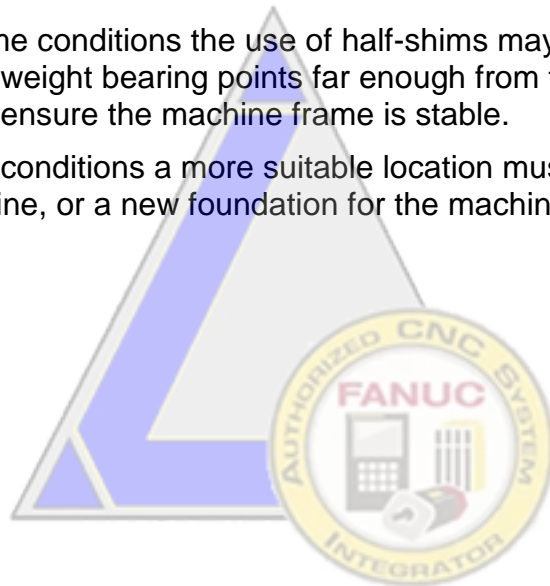
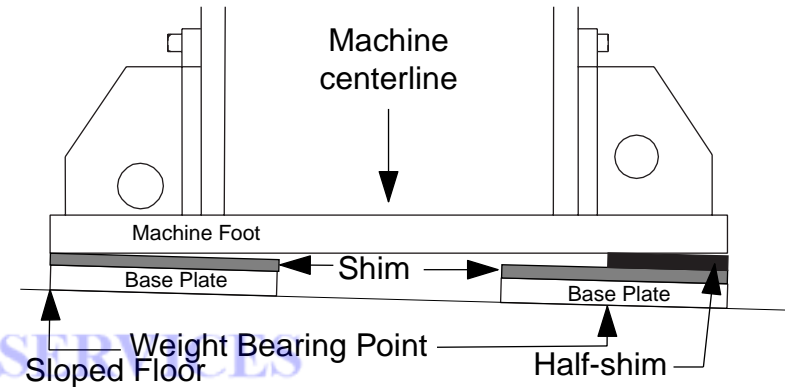
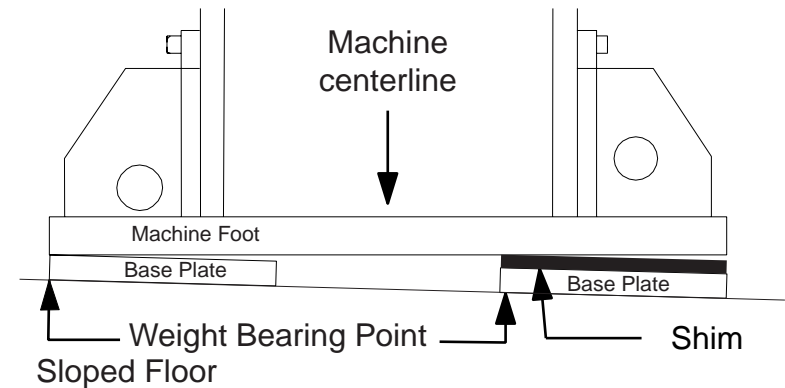

Amada Support,  
Rebuilds, Sales And  
Fanuc Control Upgrades.

LAPIS SERVICES

## Leveling Procedure

1. Determine the high end of machine frame by placing the spirit level on the turret to measure the level of the machine frame in the y-axis.
2. Use the bottle jack to lift the low end of the machine frame.
3. With the turret end of the machine frame slightly higher than the carriage end. Shim beneath both machine feet and the base plates until the machine frame measures near level on the y-axis.
4. Center the bottle jack under the carriage end of the machine frame.
5. Lift the machine frame until all weight is off the machine feet at the carriage end of the machine frame. Lift the machine frame as little as possible to take the weight off the base plates.

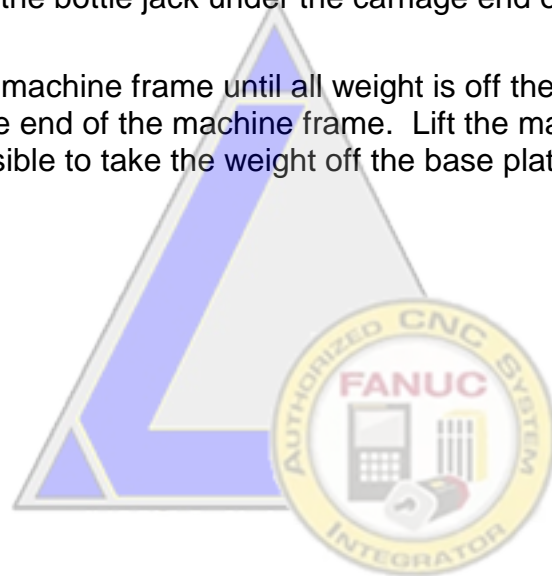
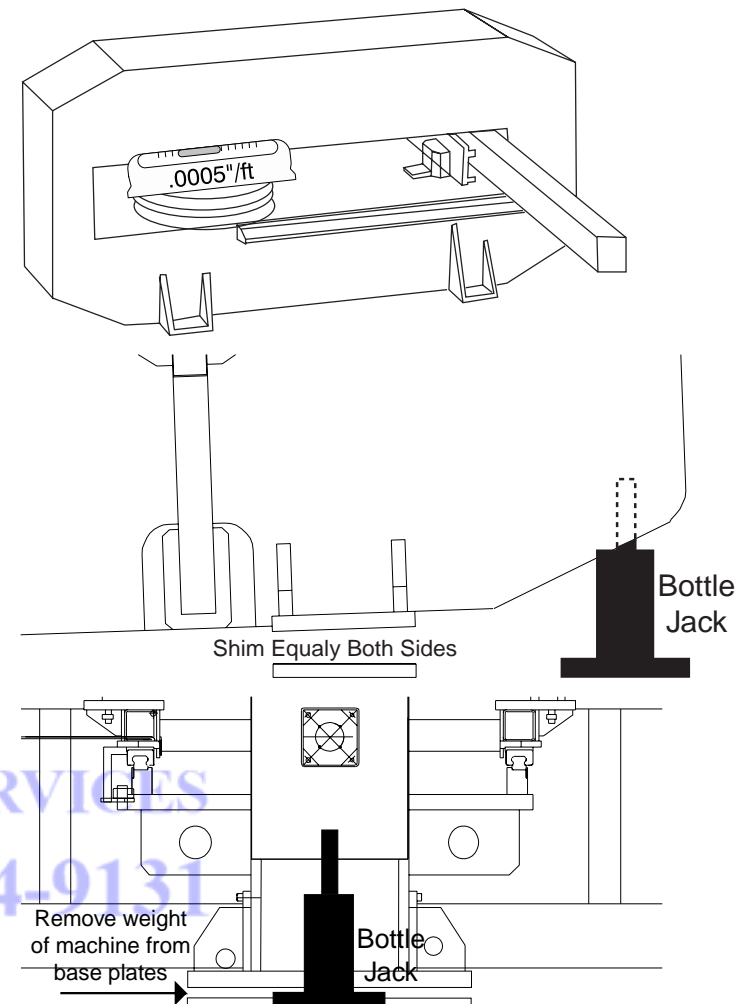

Amada Support,  
Rebuilds, Sales And  
Fanuc Control Upgrades.

LAPISINC.COM

6. With the machine supported on the bottle jack at the carriage end of the machine frame and the machine feet at the turret end of the machine frame, place the spirit level on the turret.
7. Measure and record the level of the turret in the x-axis direction.
8. Lower the machine frame to place all machine feet in contact with the leveling shims and base plates.
9. Lift the turret end of the machine frame to allow shimming between the machine feet and base plates to level the machine frame in the x-axis direction.
10. Repeat steps 5 to 9 until the machine frame measures level to 0.0005"/ft in step 7, then continue.
11. With the weight of the carriage end of the machine supported by the bottle jack. Monitor the level of the turret in the x-axis, as the bottle jack is slowly lowered to place the carriage end machine feet in contact with the base plates.
12. Any change in the level indicates that the carriage end of the machine needs to be leveled.
13. Lift the carriage end of the machine frame to allow shimming between the machine feet and base plates to level the carriage end of the machine frame in the x-axis direction.
14. Repeat steps 11 and 13 until no difference in level is noted when the machine weight is on or off the base plates and shims, then continue.

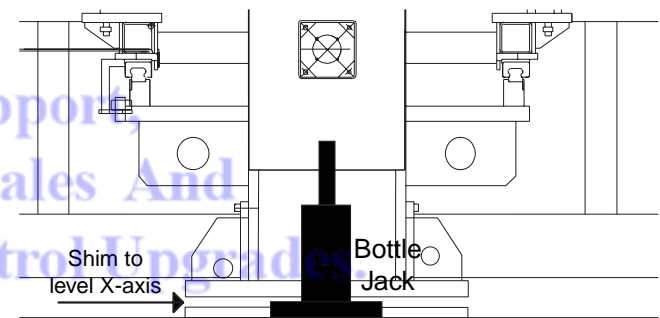
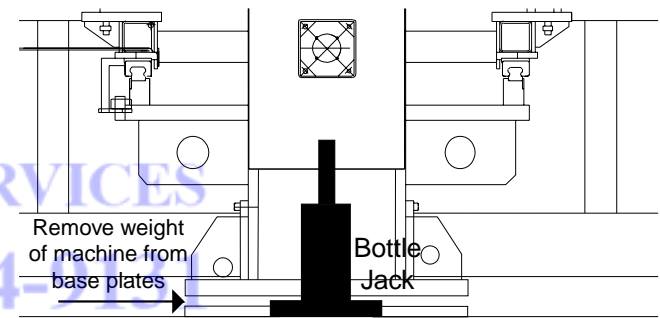
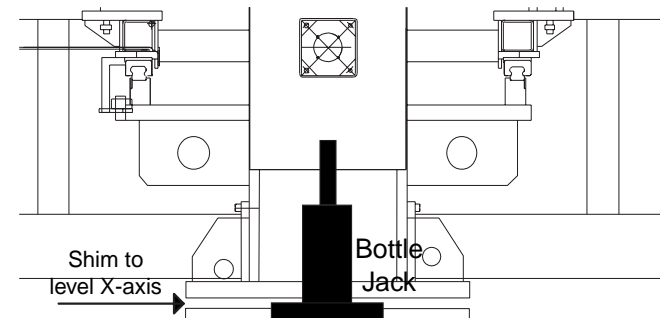
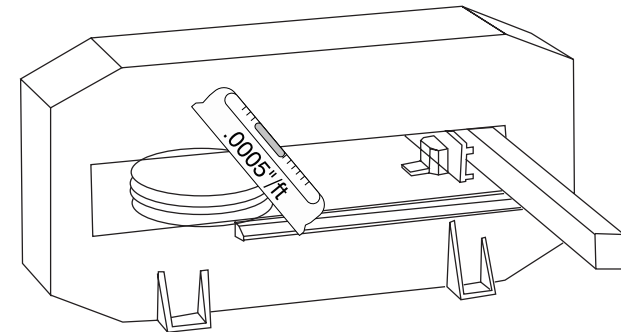

15. With all of the machine feet setting on the shims and base plates place the spirit level on the turret to measure and note the level of the machine frame in the y-axis.
16. Using the bottle jack lift the low end of the machine frame and shim equally under both machine feet to level the machine frame in the y-axis.
17. Repeat steps 15 to 16 until the machine frame measures level to 0.0005"/ft in the y-axis then continue.
18. Run the machine using the rocking test G-code to determine that the machine frame is leveled adequately. Should excessive movement of the machine frame be noticed check for the conditions discussed in *Floor Condition Crowned* and *Floor Condition Sloped*
19. Tighten the anchor bolt nuts to prevent the machine frame from moving when in use. Monitor the machine level while tightening the anchor bolts to assure the machine level is not changed.

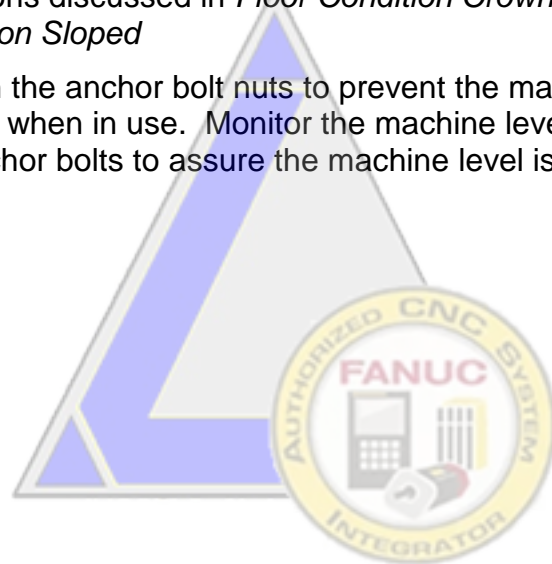
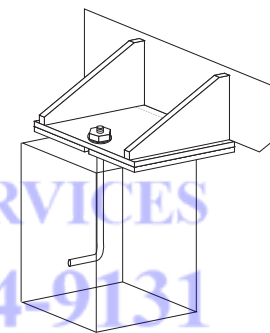
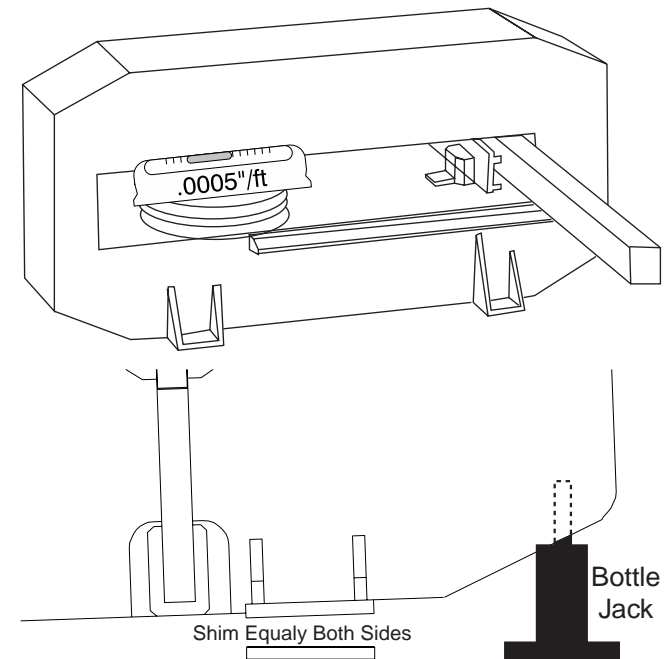

LAPIS SERVICES  
(215) 464-9131

Amada Support,  
Rebuilds, Sales And  
Fanuc Control Upgrades.

LAPISINC.COM